



TECHNIC

42002





1

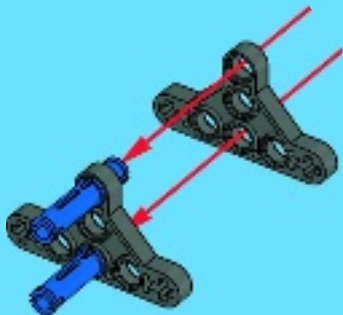

2



2

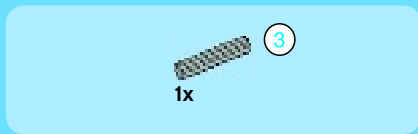

3

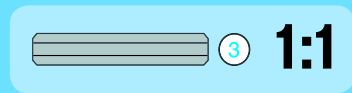
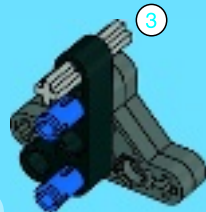

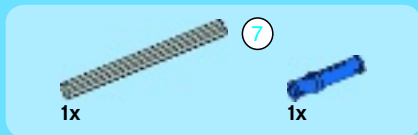

4

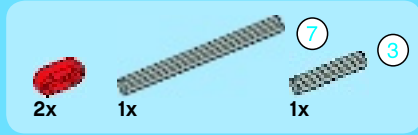

5

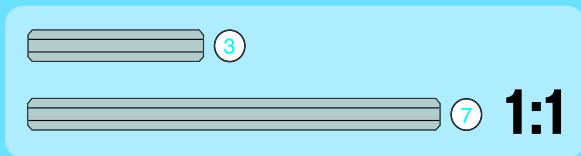
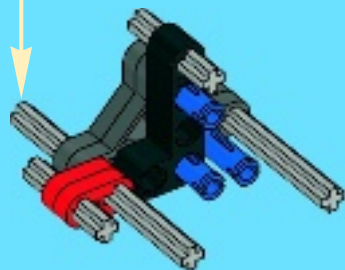
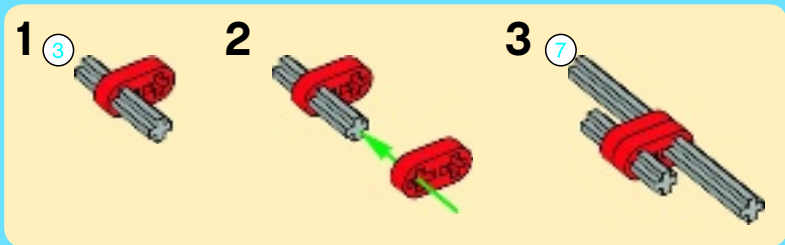

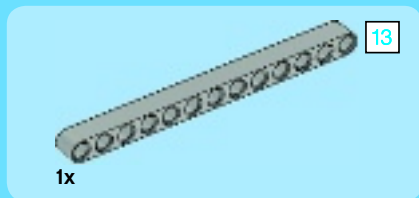

6

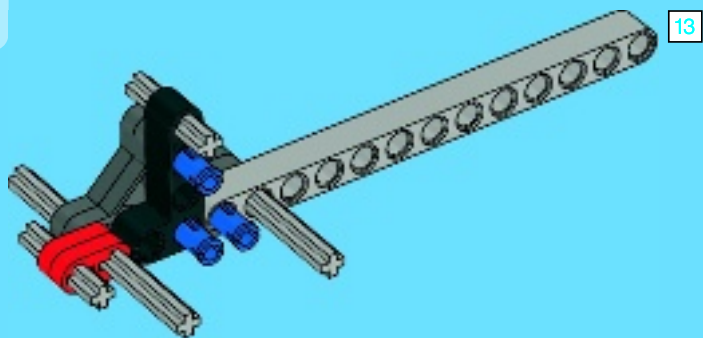

7

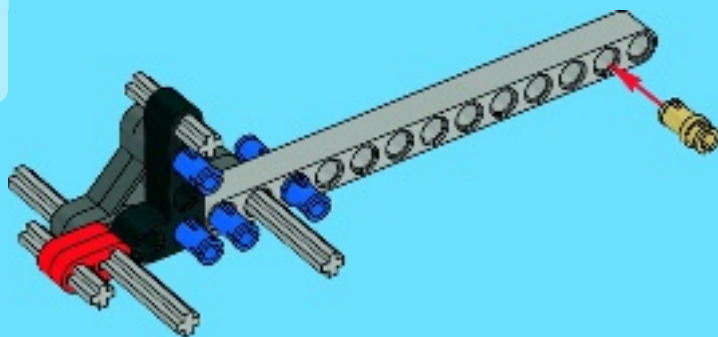



2x

8

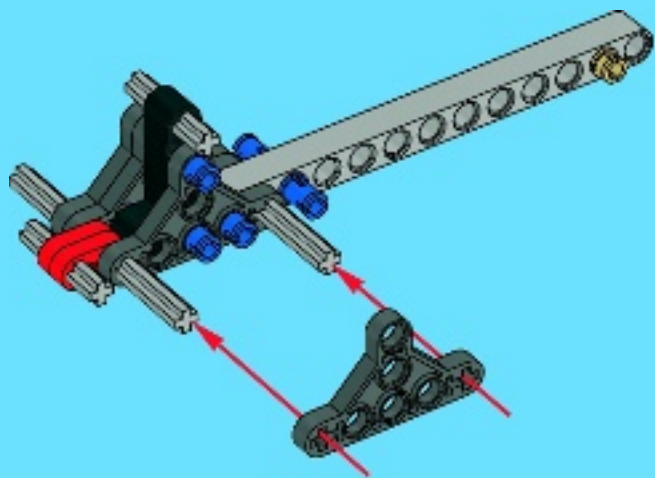

2x

9

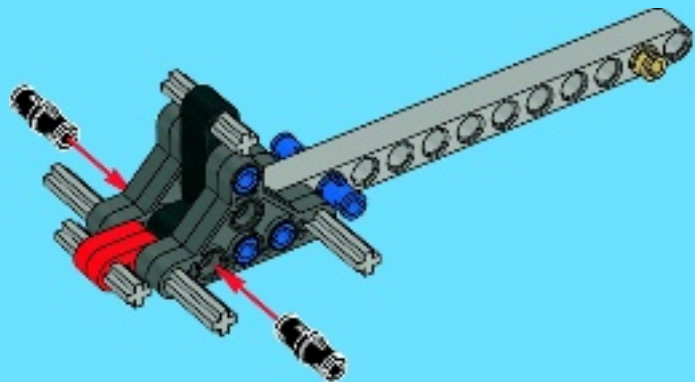

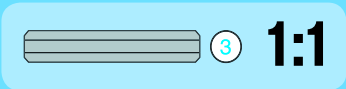
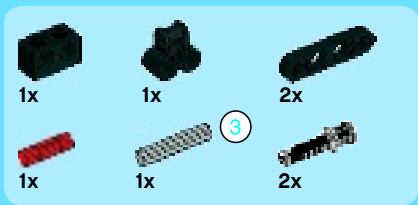

10

1



2



3



4

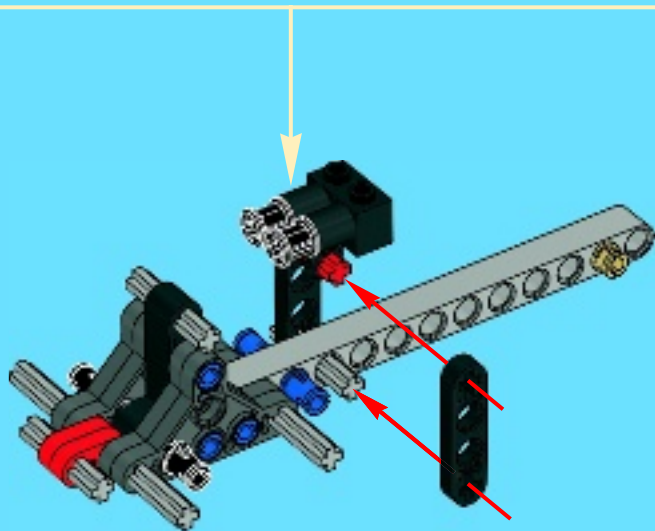

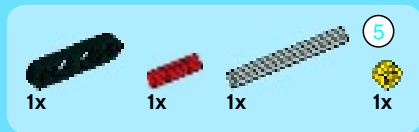

11

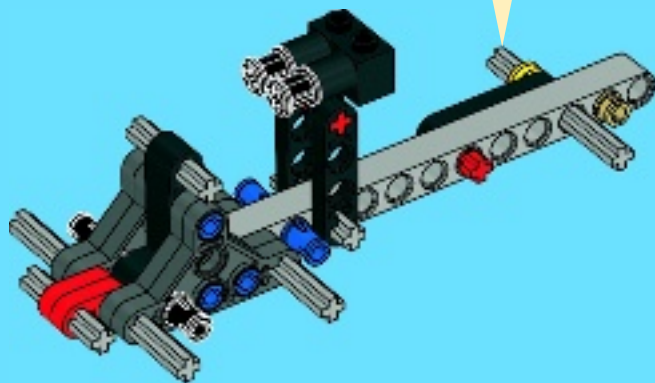
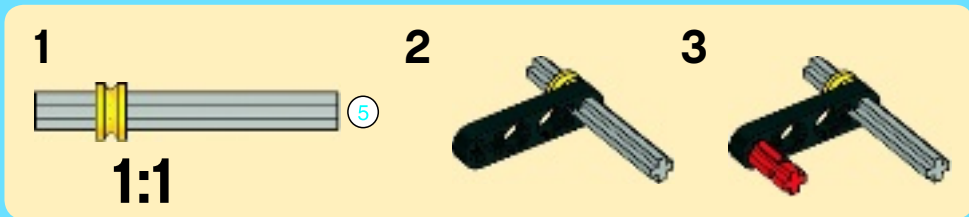



1x



1x

12

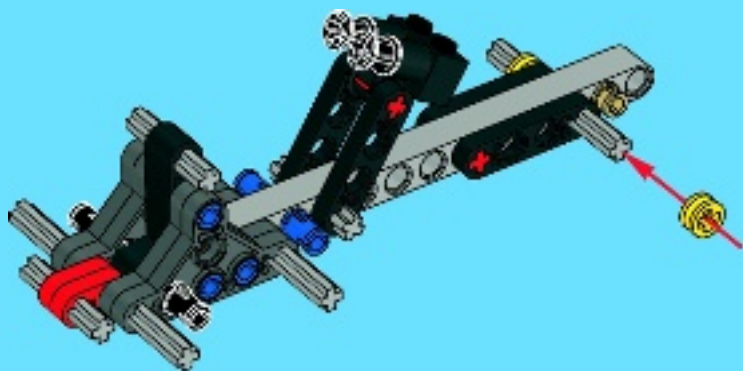



 ③ 1:1

2

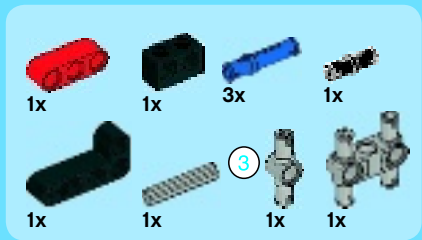

13

1



3

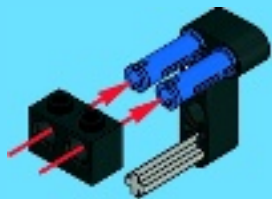

4



5

1

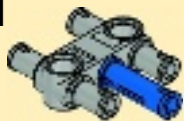

2

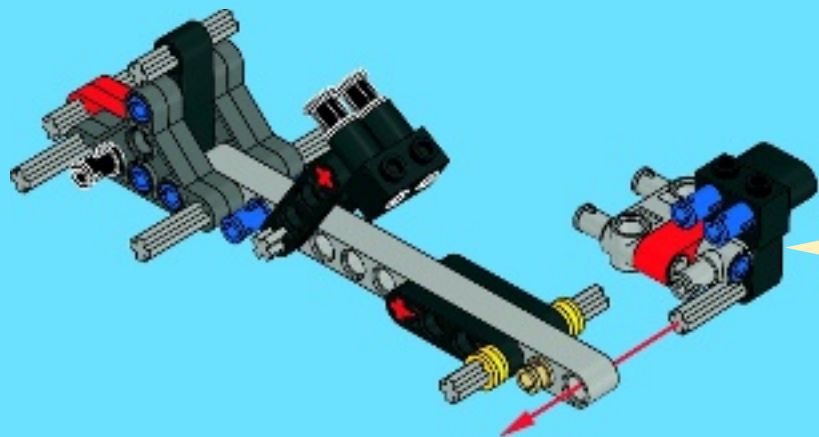
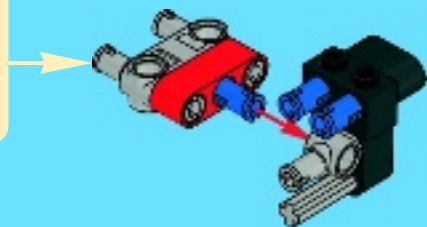

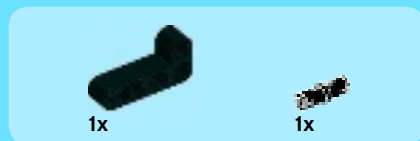

14

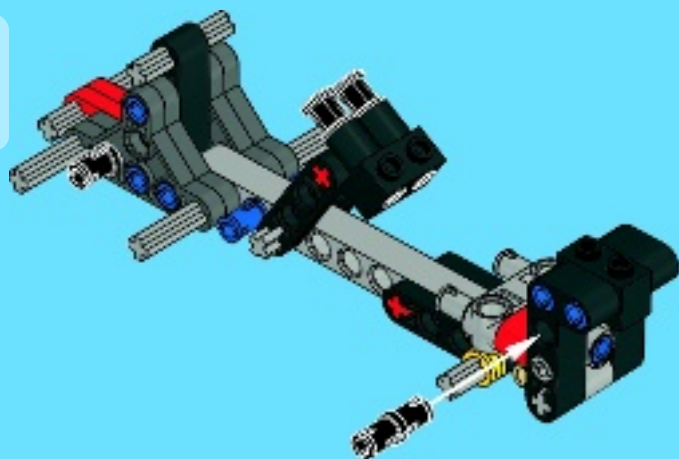

15

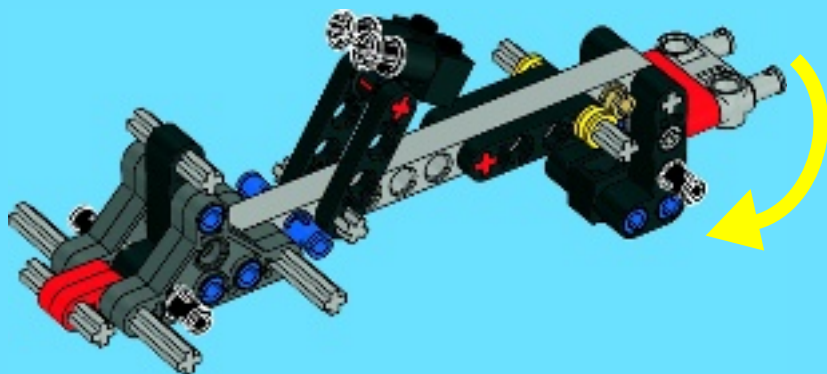



16

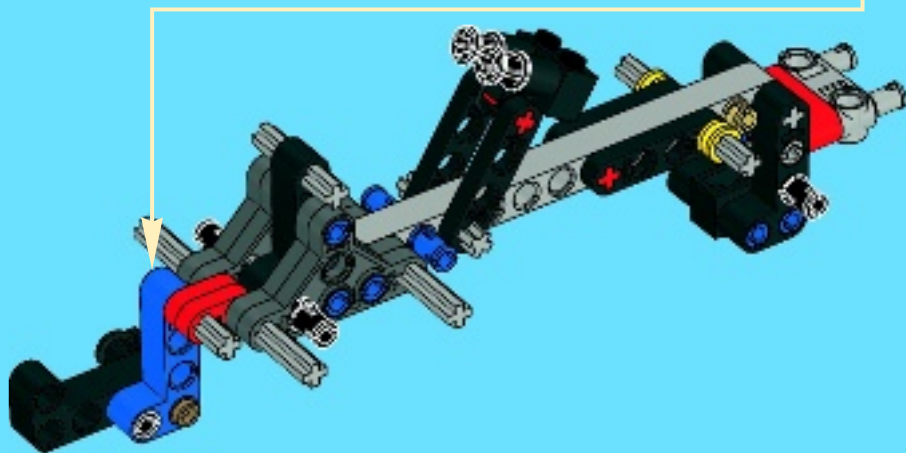

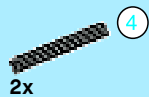

1:1

17

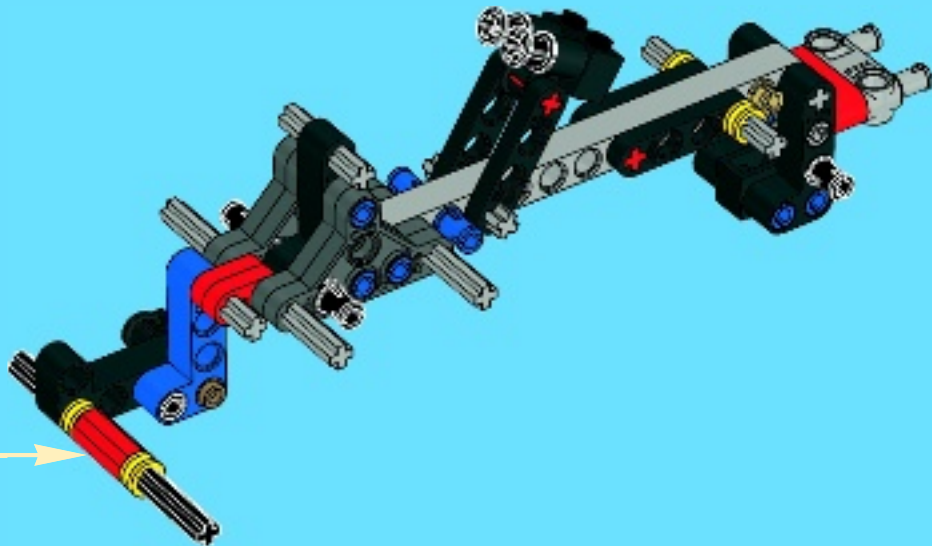
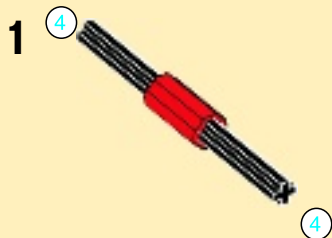



18

1

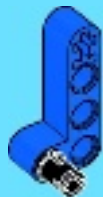

2



3

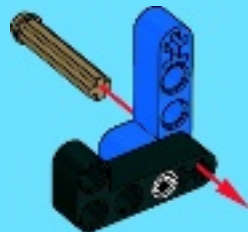

4



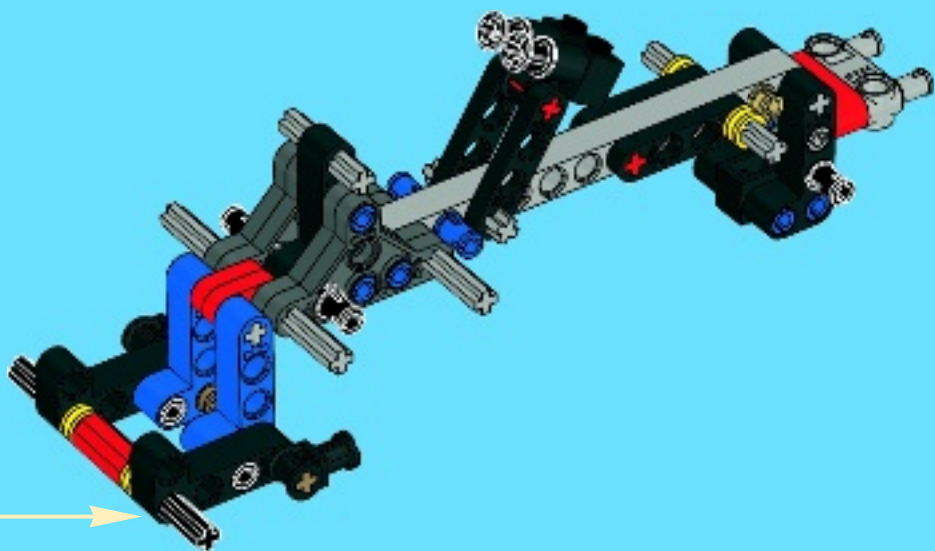



2x

19

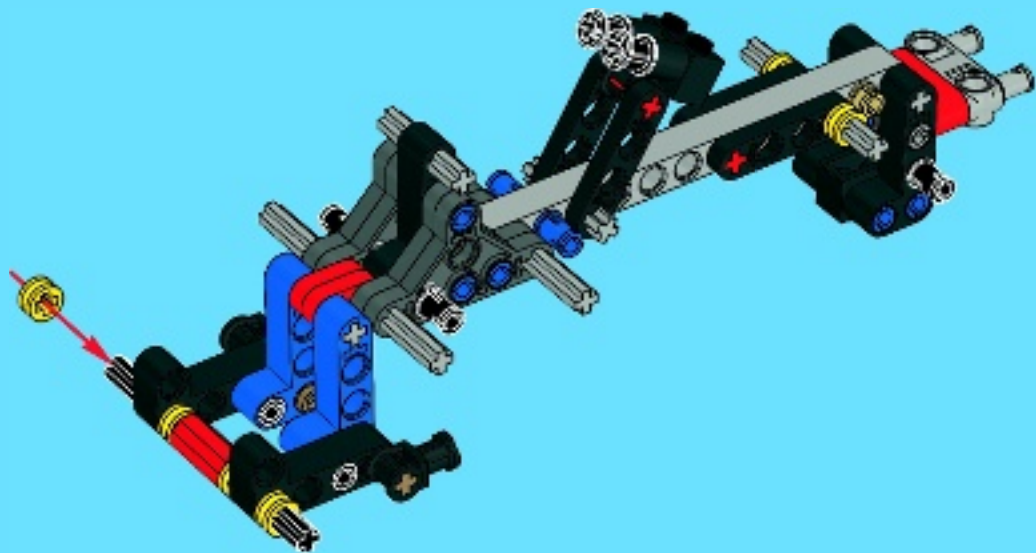

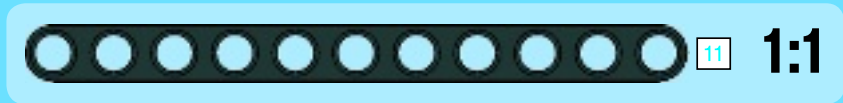

20

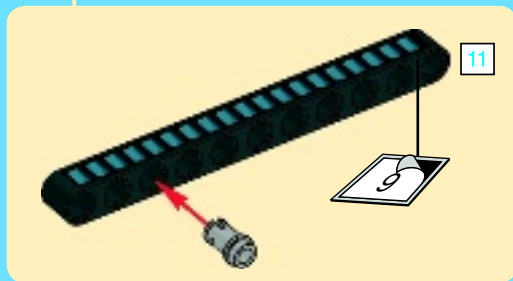
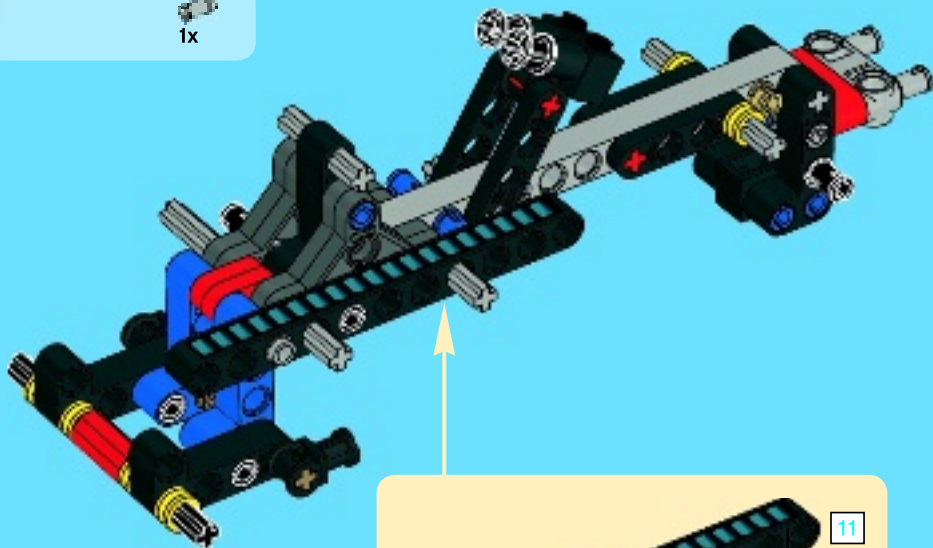

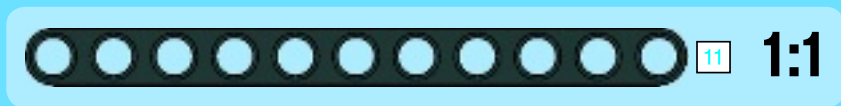

21

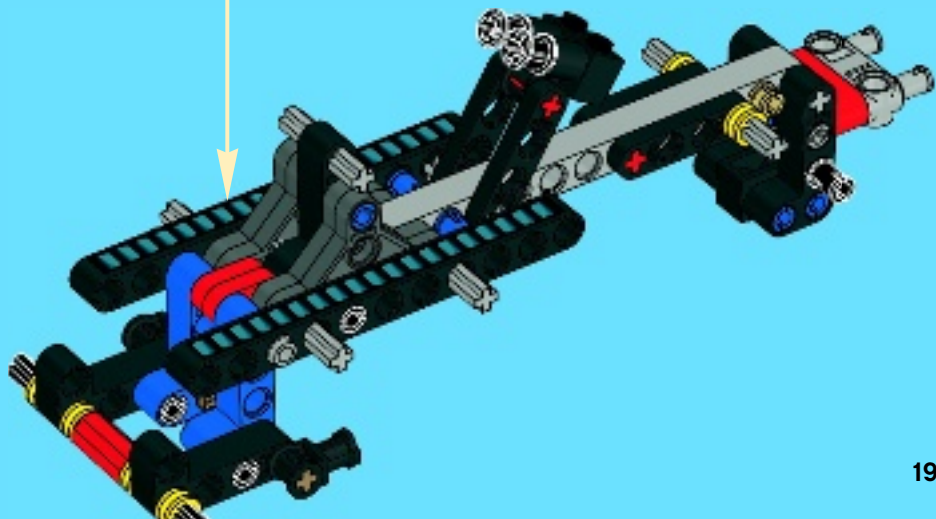
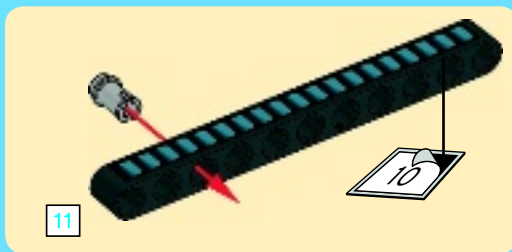

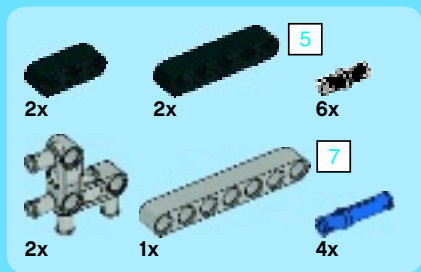

22

1

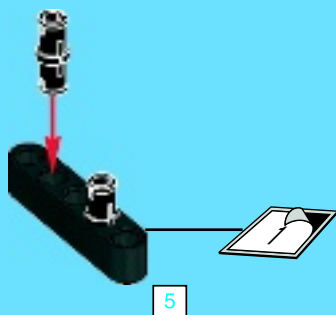

2

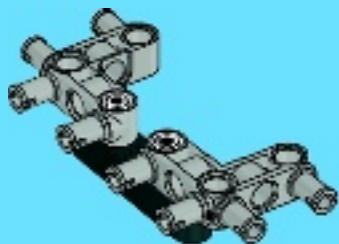

3

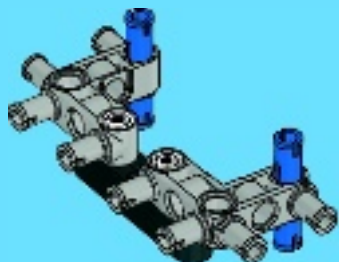

4

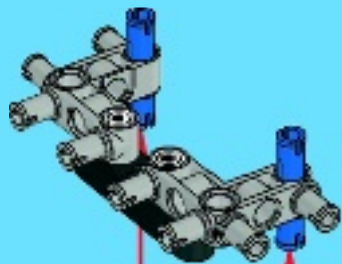

5



6

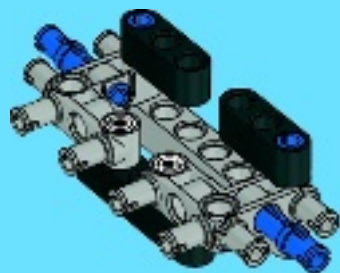

7

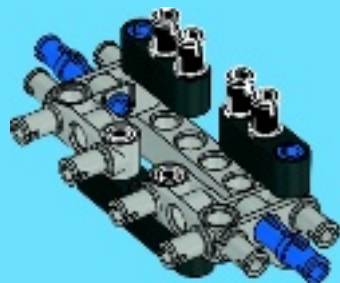

8

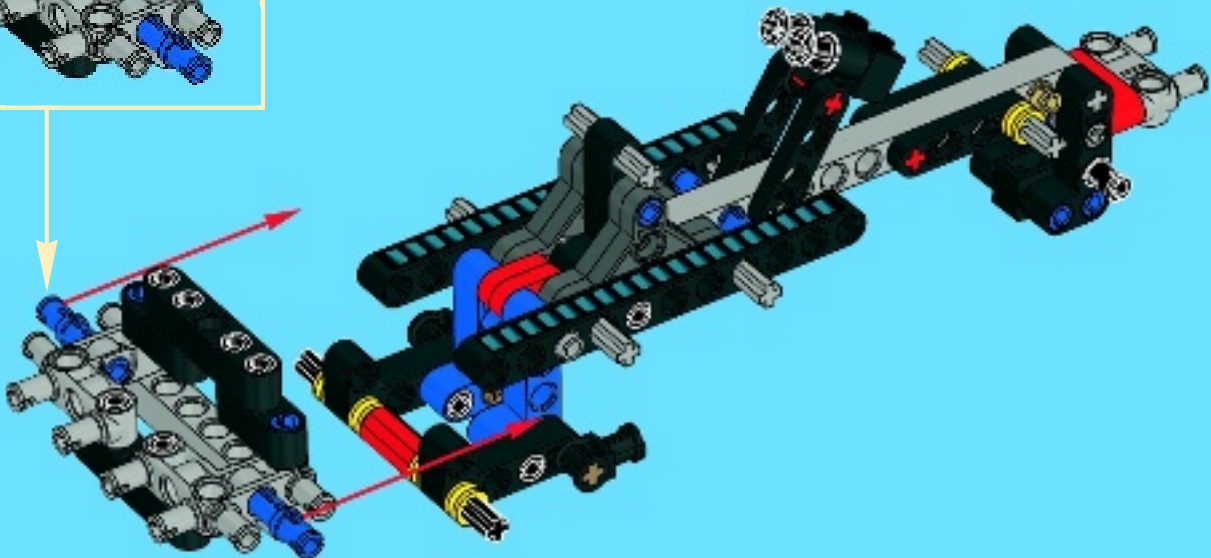
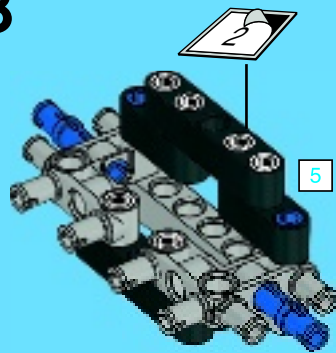

23

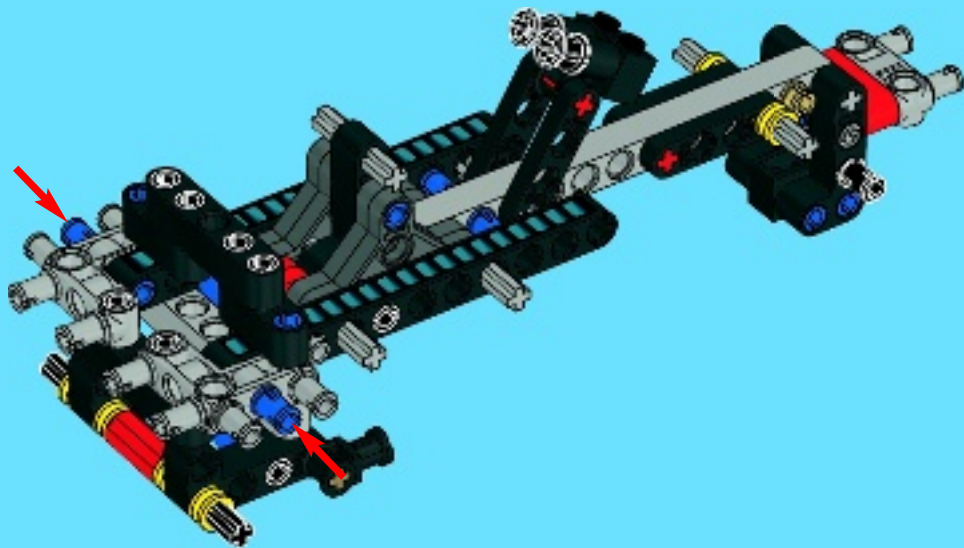

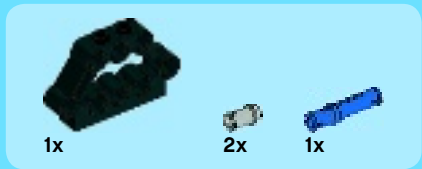

1

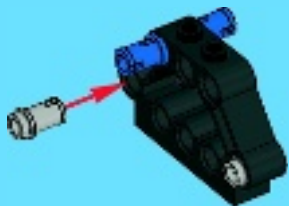

2

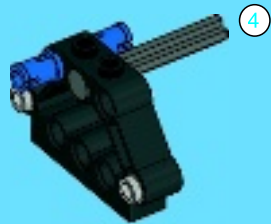

3

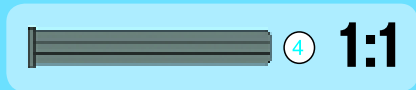
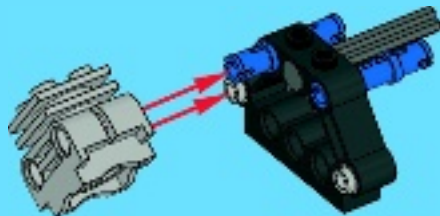

1:1



2x



2x



2x

4



1

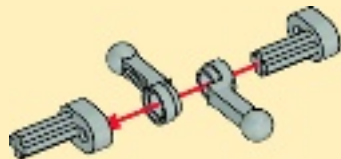

2

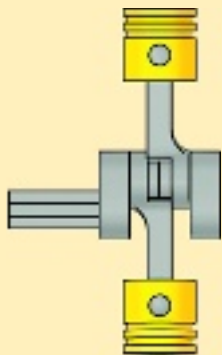

1:1



1x

4

5

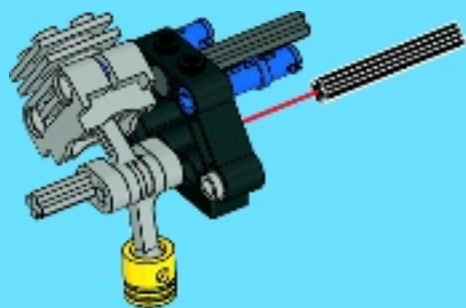

4

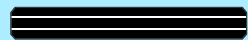

4

1:1



1x

6

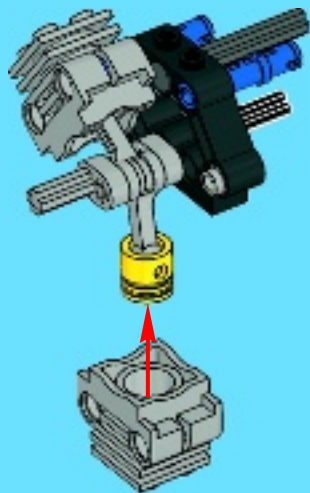

7

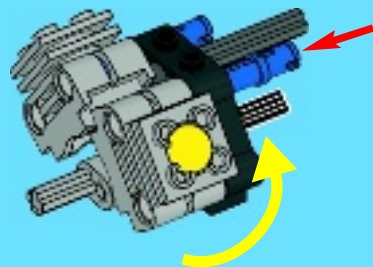

2x

8

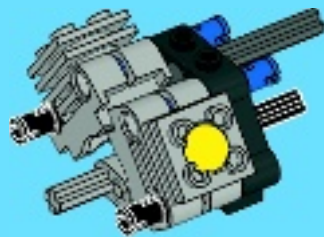



1x

9



2x

10



2x



2x

11

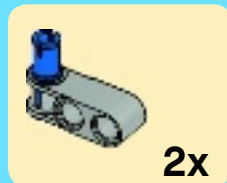

2x

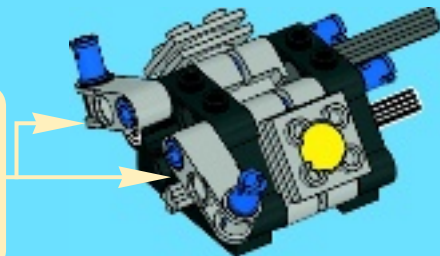

1x

12

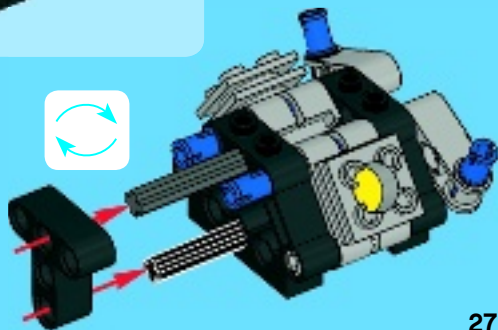



1x



1x



2x

13

1



2



1x



1x

14



24

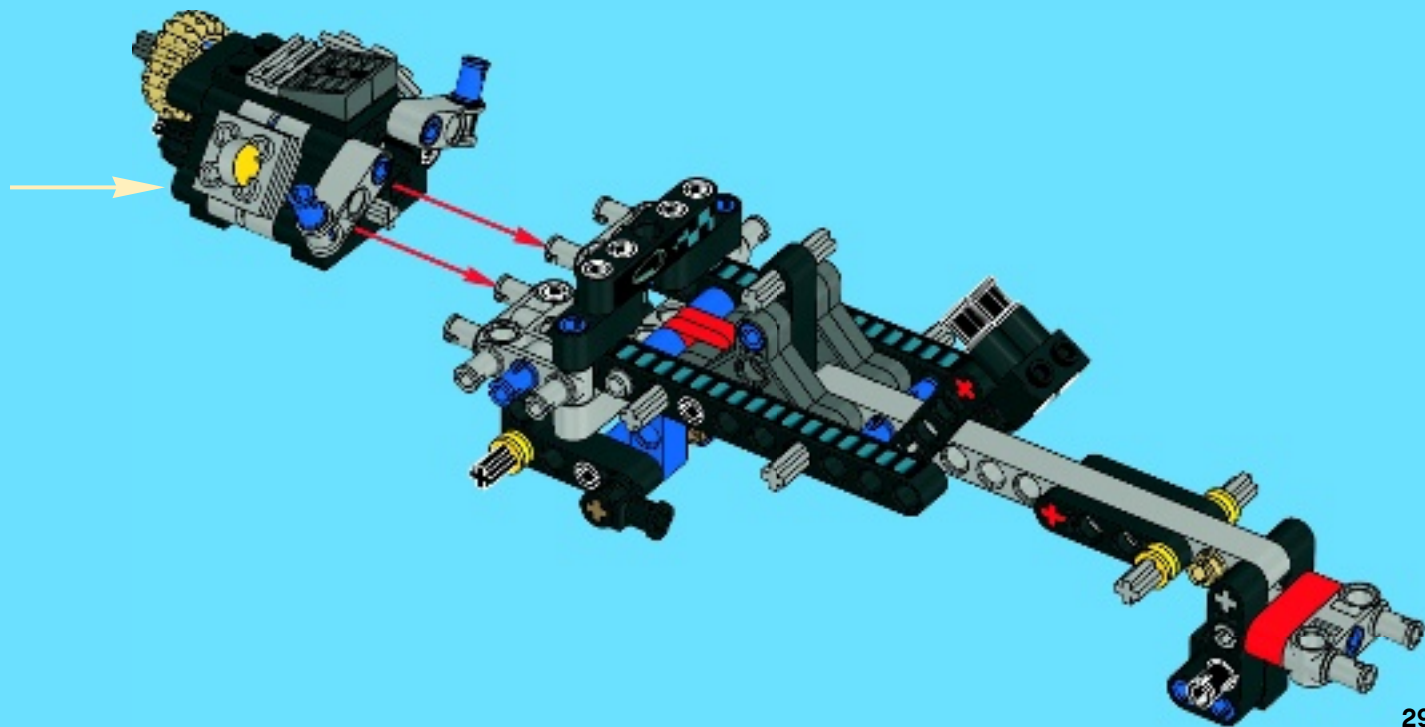

25

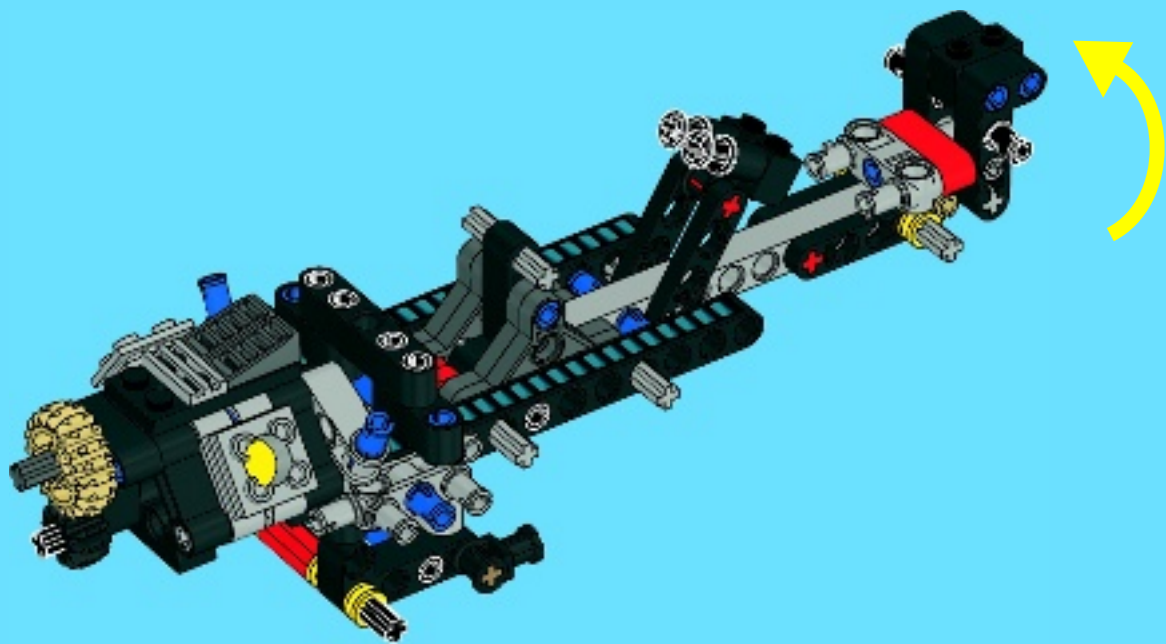



26

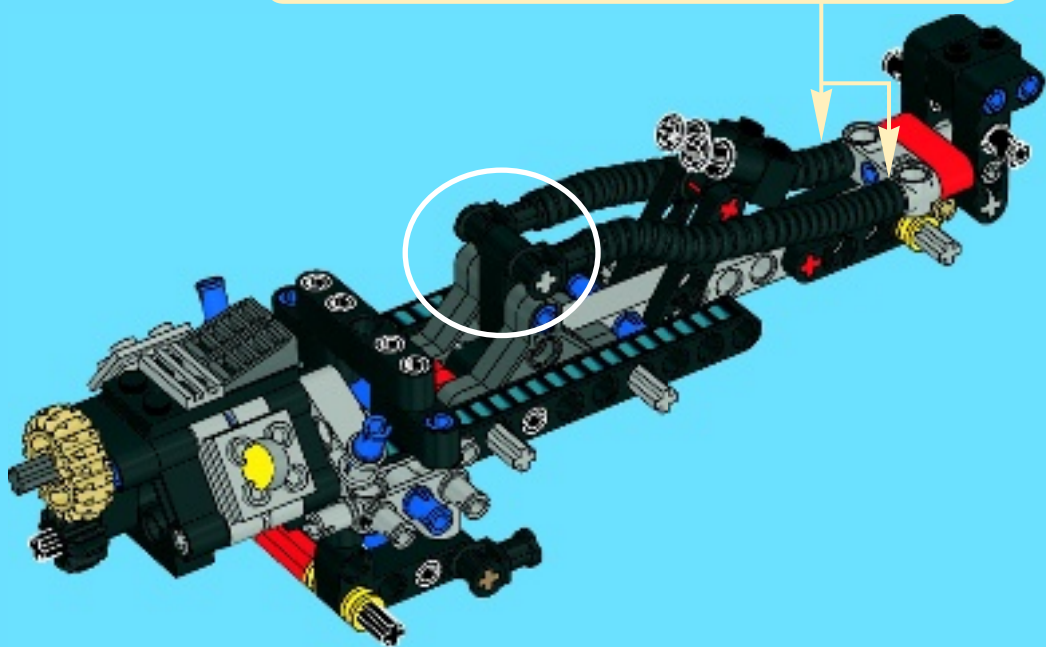

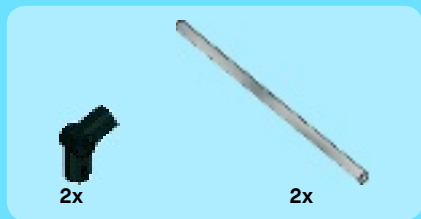

27

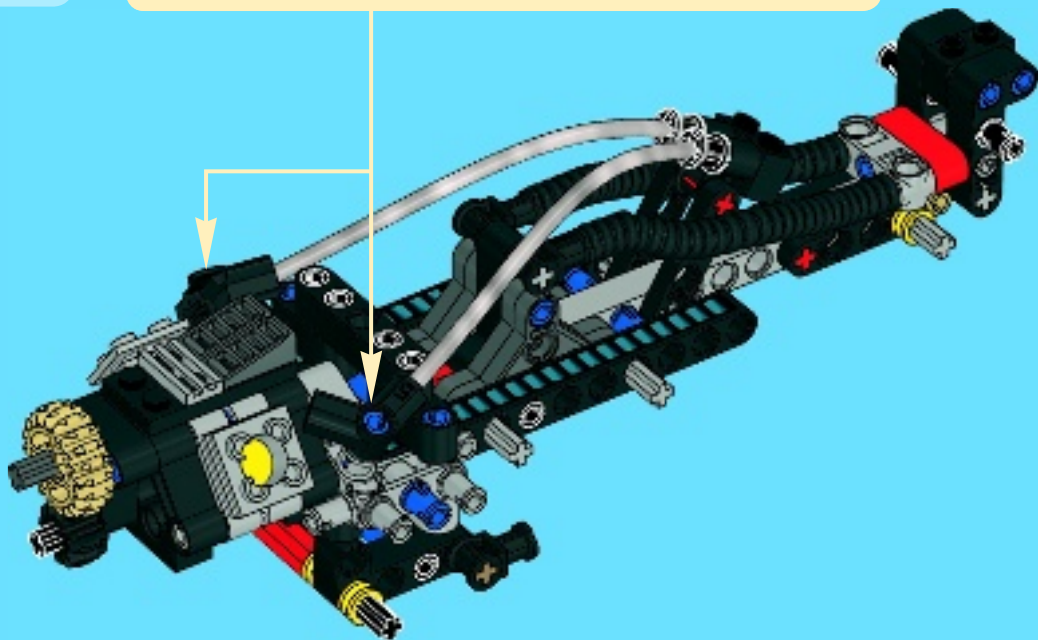



28

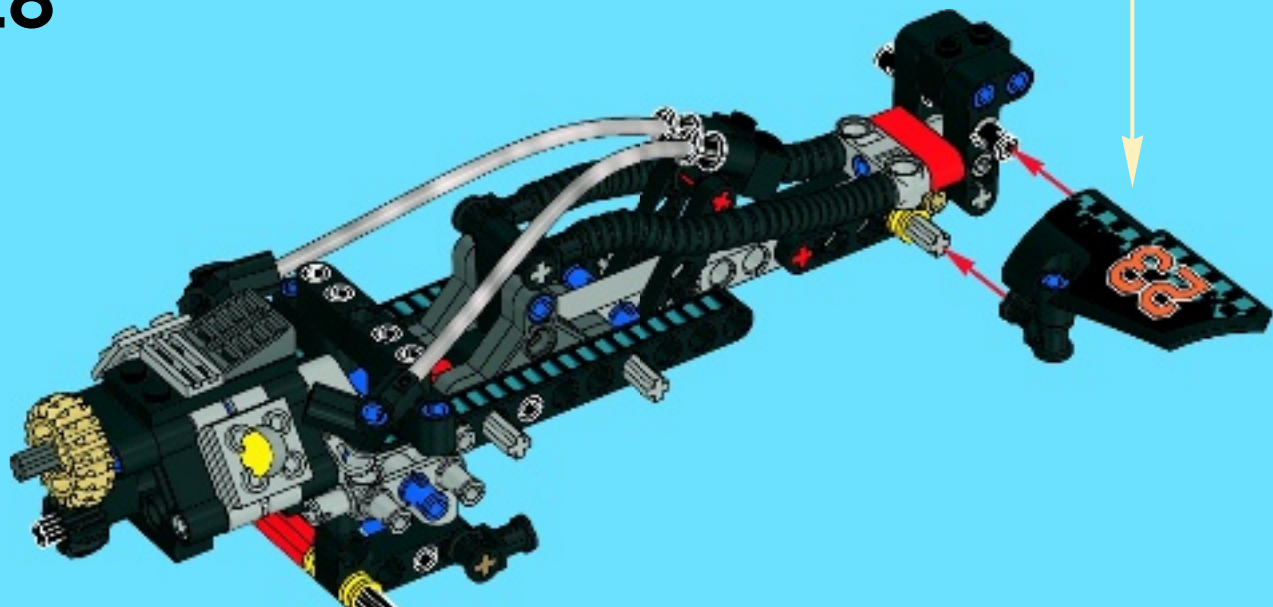

30

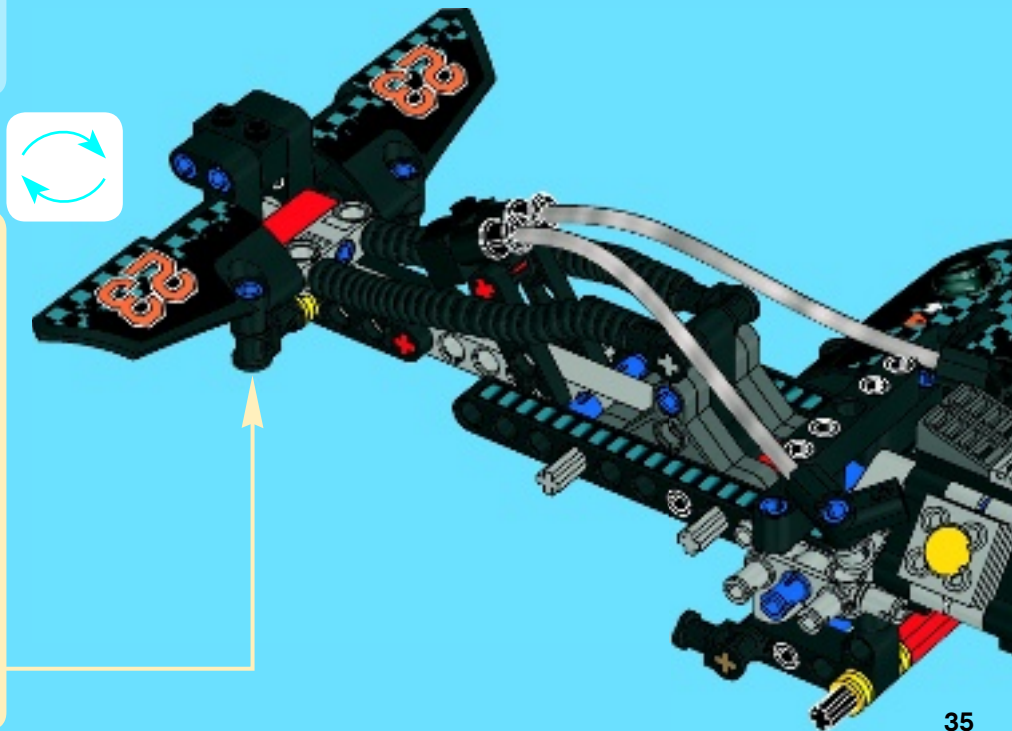



31

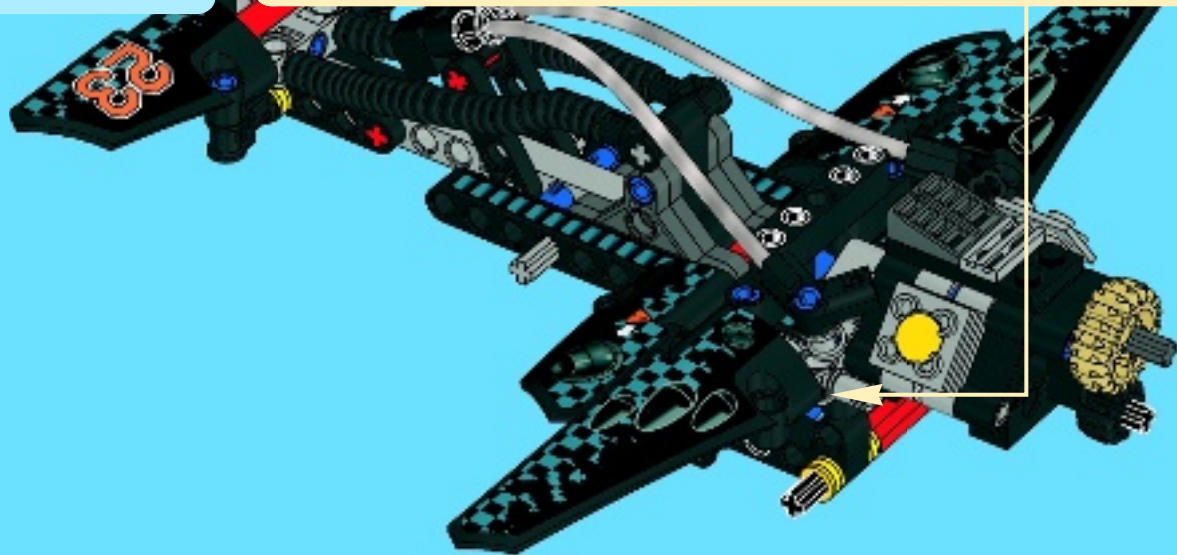



2x



2x



1x

32

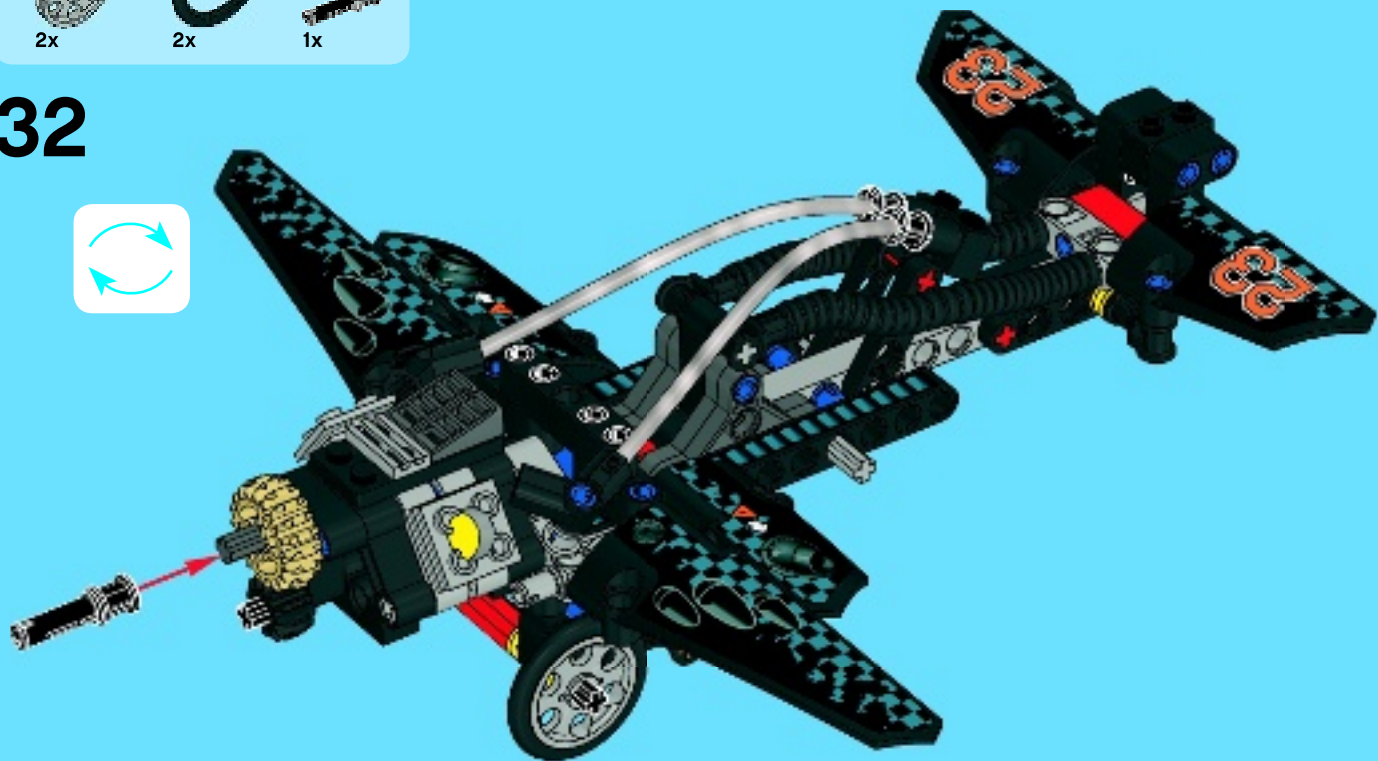



1x

33

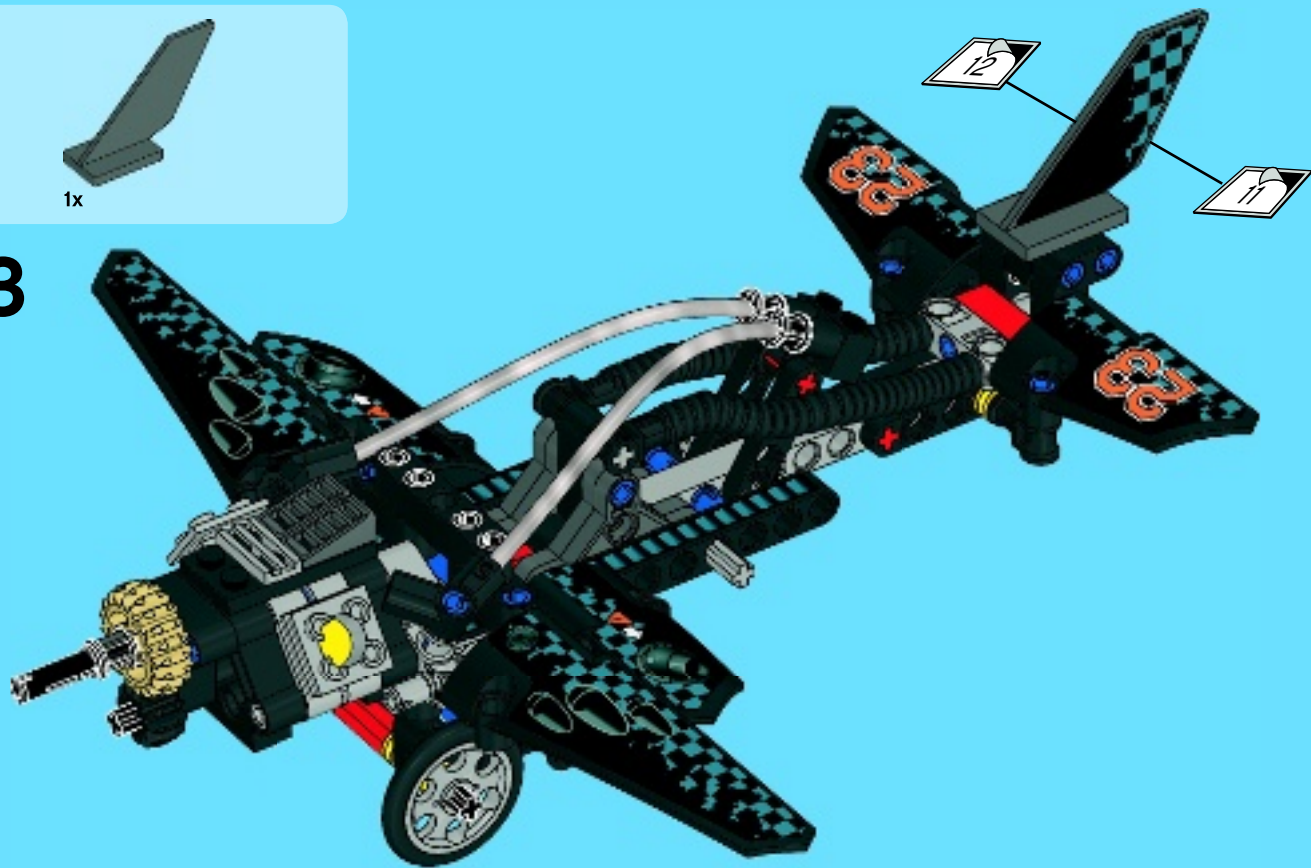



1x

34

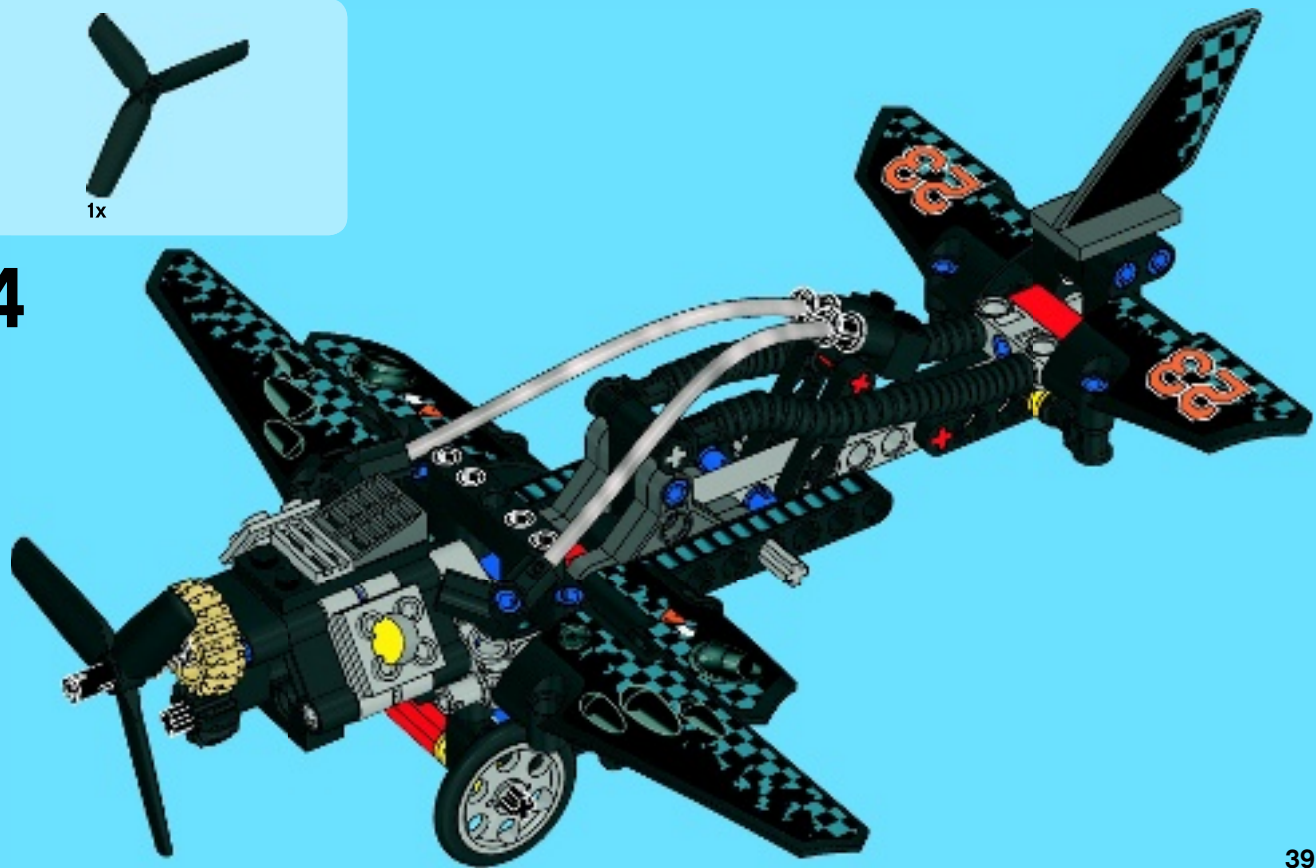



WIN!

Go to www.LEGOsurvey.com/product to fill out a survey for a chance to win a cool LEGO® Product.

No purchase necessary.

Open to all residents where not prohibited.



www.LEGOsurvey.com/product

GEWINNE!

Nimm an der Umfrage auf www.LEGOsurvey.com/product teil und hab die Chance ein cooles LEGO® Produkt zu gewinnen!

Die Teilnahme am Gewinnspiel führt zu keinerlei Kaufverpflichtungen. Teilnahme in allen nicht ausgeschlossenen Ländern möglich.

WIN!

Ga naar www.LEGOsurvey.com/product, vul een enquêteformulier in en maak kans op een cool LEGO® product.

Geen aankoopverplichting. Iedereen mag deelnemen, uitgezonderd ingezetenden van landen waar een enquêteverbod geldt.

GAGNE!

Visite www.LEGOsurvey.com/product pour répondre à un questionnaire et avoir une chance de gagner un produit LEGO® très cool!

Aucune obligation d'achat. Ouvert à tous les résidents des pays autorisés.

当てよう!

www.LEGOsurvey.com/product にアクセスして、アンケートにご記入ください。当選者にはレゴ®製品を差し上げます。

お買い上げの必要はありません。禁止されていない限り、すべての皆様にご利用いただけます。



LEGO.com

6033734 / 6033735

LEGO and the LEGO logo are trademarks of the/son des marques de commerce de/son marcas registradas de LEGO Group. ©2013 The LEGO Group.