



## MASTER-TOUCH Premium



E-5770  
SE E-5775

EN

### Charcoal Barbecue Owner's Guide

Do not discard. This owner's guide contains important product dangers, warnings, and cautions. For assembly instructions, refer to the assembly guide. Do not use the barbecue indoors!

Visit [weber.com](#), select your country of origin, and register your barbecue today.

**69143**

enGB - GREAT BRITAIN

10/31/18

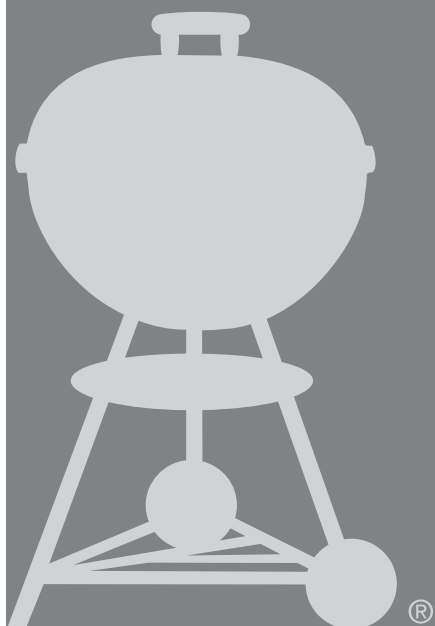



# SAFETY

Failure to follow the DANGERS, WARNINGS, and CAUTIONS contained in this Owner's Guide may result in serious bodily injury or death, or may result in a fire or an explosion causing damage to property.

Please read all safety information contained in this Owner's Guide before operating this barbecue.

- ⚠ WARNING! Do not use indoors! This barbecue is designed for outdoor use in a well-ventilated area and is not intended for and should never be used as a heater. If used indoors, toxic fumes will accumulate and cause serious bodily injury or death.
- ⚠ WARNING! This barbecue will become very hot, do not move it during operation.
- ⚠ WARNING! Keep children and pets away.
- ⚠ WARNING! Do not use spirit or petrol for lighting or re-lighting! Use only firelighters complying to EN 1860-3!
- ⚠ WARNING! Do not cook before the fuel has a coating of ash.
- ⚠ WARNING! Do not use the barbecue in a confined and/or habitable space e.g. houses, tents, caravans, motor homes, boats. Danger of carbon monoxide poisoning fatality.

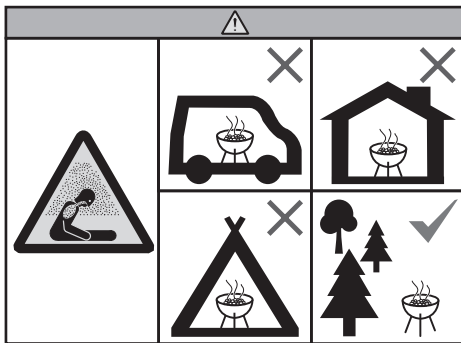

## DANGERS

- ⚠ Do not use in a garage, building, breezeway, or any other enclosed area.
- ⚠ Do not add charcoal starter fluid or charcoal impregnated with charcoal lighter fluid to hot or warm charcoal. Put the cap on starter fluid after use, and place a safe distance away from the barbecue.
- ⚠ Keep the cooking area clear of flammable vapour and liquids, such as petrol, alcohol, etc., and combustible material.

## WARNINGS

- ⚠ Do not use this barbecue unless all parts are in place. This barbecue must be properly assembled according to the assembly instructions. Improper assembly may be dangerous.
- ⚠ Never use this barbecue without the ash catcher installed.
- ⚠ Do not use this barbecue under any overhead combustible construction.
- ⚠ The use of alcohol or prescription or non-prescription drugs may impair the consumer's ability to properly assemble or safely operate the barbecue.
- ⚠ Exercise caution when operating the barbecue. It will be hot during cooking or cleaning, and should never be left unattended.

- ⚠ Do not use petrol, alcohol, or other highly volatile fluids to ignite charcoal. If using charcoal starter fluid (not recommended), be aware that fluid can collect in the ash catcher and ignite, resulting in a fire below the bowl. Remove starter fluid from the ash catcher before lighting charcoal.

- ⚠ This barbecue is not intended to be installed in or on recreational vehicles and/or boats.
- ⚠ Do not use this barbecue within five feet (1.5 m) of any combustible material. Combustible materials include, but are not limited to, wood or treated wood decks, patios, and porches.

- ⚠ Keep the barbecue on a secure, level surface at all times, clear of combustible material.

- ⚠ Do not place barbecue on glass or a combustible surface.

- ⚠ Do not use barbecue in high winds.

- ⚠ Do not wear clothing with loose flowing sleeves while lighting or using the barbecue.

- ⚠ Never touch the cooking or charcoal grate, ashes, charcoal, or the barbecue to see if they are hot.

- ⚠ Extinguish charcoal when finished cooking. To extinguish, close bowl vent and lid damper and place lid on bowl.

- ⚠ Use heat-resistant barbecue mitts or gloves (conforming to EN 407, Contact Heat rating level 2 or greater) while cooking, adjusting air vents (dampers), adding charcoal, and handling thermometer or lid.

- ⚠ Use proper tools, with long, heat-resistant handles.

- ⚠ Always put charcoal on top of the charcoal (lower) grate. Do not put charcoal directly in the bottom of the bowl.

- ⚠ Never dump hot charcoal where it might be stepped on or be a fire hazard. Never dump ashes or charcoal before they are fully extinguished.

- ⚠ Do not store the barbecue away until ashes and charcoal are fully extinguished.

- ⚠ Do not remove ashes until all charcoal is completely burned out and fully extinguished and the barbecue is cool.

- ⚠ Keep electrical wires and cords away from the hot surfaces of the barbecue and away from high traffic areas.

## CAUTIONS

- ⚠ Do not use water to control flare-ups or to extinguish charcoal.

- ⚠ Lining the bowl with aluminium foil will obstruct the air flow. Instead, use a drip pan to catch drippings from meat when cooking using the indirect method.

- ⚠ Barbecue brushes should be checked for loose bristles and excessive wear on a regular basis. Replace brush if any loose bristles are found on the cooking grate or brush. WEBER recommends purchasing a new stainless steel bristle barbecue brush at the beginning of every spring.

## ADDITIONAL WARNINGS

- ⚠ Open the lid to release tension on the hinge springs before removing the lid from the hinge.



# WARRANTY

Thank you for purchasing a WEBER product. Weber-Stephen Products LLC, 1415 S. Roselle Road, Palatine, Illinois 60067 ("WEBER") prides itself on delivering a safe, durable, and reliable product.

This is WEBER's voluntary warranty provided to you at no extra charge. It contains the information you will need to have your WEBER product repaired in the unlikely event of a failure or defect.

**Pursuant to applicable laws, the customer has several rights in case the product is defective. Those rights include supplementary performance or replacement, abatement of the purchasing price, and compensation. In the European Union, for example, this would be a two-year statutory warranty starting on the date of the handover of the product. These and other statutory rights remain unaffected by this warranty provision. In fact, this warranty grants additional rights to the owner that are independent from statutory warranty provisions.**

## **WEBER'S VOLUNTARY WARRANTY**

WEBER warrants, to the purchaser of the WEBER product (or in the case of a gift or promotional situation, the person for whom it was purchased as a gift or promotional item), that the WEBER product is free from defects in material and workmanship for the period(s) of time specified below when assembled and operated in accordance with the accompanying Owner's Manual. (Note: If you lose or misplace your WEBER Owner's Manual, a replacement is available online at [weber.com](http://weber.com), or such country-specific website to which you may be redirected.) Under normal, private single family home or apartment use and maintenance, WEBER agrees within the framework of this warranty to repair or replace defective parts within the applicable time periods, limitations, and exclusions listed below. TO THE EXTENT ALLOWABLE BY APPLICABLE LAW, THIS WARRANTY IS EXTENDED ONLY TO THE ORIGINAL PURCHASER AND IS NOT TRANSFERABLE TO SUBSEQUENT OWNERS, EXCEPT IN THE CASE OF GIFTS AND PROMOTIONAL ITEMS AS NOTED ABOVE.

## **OWNER'S RESPONSIBILITIES UNDER THIS WARRANTY**

To ensure trouble-free warranty coverage, it is important (but it is not required) that you register your WEBER product online at [weber.com](http://weber.com), or such country-specific website to which you may be redirected. Please also retain your original sales receipt and/or invoice. Registering your WEBER product confirms your warranty coverage and provides a direct link between you and WEBER in case we need to contact you.

The above warranty only applies if the owner takes reasonable care of the WEBER product by following all assembly instructions, usage instructions, and preventative maintenance as outlined in the accompanying Owner's Manual, unless the owner can prove that the defect or failure is independent of non-compliance with the above mentioned obligations. If you live in a coastal area, or have your product located near a pool, maintenance includes regular washing and rinsing of the exterior surfaces as outlined in the accompanying Owner's Manual.

## **WARRANTY HANDLING / EXCLUSION OF WARRANTY**

If you believe that you have a part which is covered by this warranty, please contact WEBER Customer Service using the contact information on our website ([weber.com](http://weber.com), or such country-specific website to which you may be redirected). WEBER will, upon investigation, repair or replace (at its option) a defective part that is covered by this warranty. In the event that repair or replacement are not possible, WEBER may choose (at its option) to replace the barbecue in question with a new barbecue of equal or greater value. WEBER may ask you to return parts for inspection, shipping charges to be pre-paid.

This warranty lapses if there is damage, deterioration, discolouration, and/or rust for which WEBER is not responsible caused by:

- Abuse, misuse, alteration, modification, misapplication, vandalism, neglect, improper assembly or installation, or failure to properly perform normal and routine maintenance;
- Insects and rodents;
- Exposure to salt air and/or chlorine sources such as swimming pools and hot tubs/spas;
- Severe weather conditions such as hail, hurricanes, earthquakes, tsunamis or surges, tornadoes or severe storms.

The use and/or installation of parts on your WEBER product that are not genuine WEBER parts will void this warranty, and any damage that results is not covered by this warranty.

## **PRODUCT WARRANTY PERIODS**

Bowl, lid, and centre ring:  
10 years, rust through/burn through

Stainless steel components:  
5 years, rust through/burn through

ONE-TOUCH cleaning system:  
5 years, rust through/burn through

Plastic components:  
5 years, excluding fading or discolouration

All remaining parts:  
2 years

## **DISCLAIMERS**

**APART FROM THE WARRANTY AND DISCLAIMERS AS DESCRIBED IN THIS WARRANTY STATEMENT, THERE ARE EXPLICITLY NO FURTHER WARRANTY OR VOLUNTARY DECLARATIONS OF LIABILITY GIVEN HERE WHICH GO BEYOND THE STATUTORY LIABILITY APPLYING TO WEBER. THE PRESENT WARRANTY STATEMENT ALSO DOES NOT LIMIT OR EXCLUDE SITUATIONS OR CLAIMS WHERE WEBER HAS MANDATORY LIABILITY AS PRESCRIBED BY STATUTE.**

**NO WARRANTIES SHALL APPLY AFTER THE APPLICABLE PERIODS OF THIS WARRANTY. NO OTHER WARRANTIES GIVEN BY ANY PERSON, INCLUDING A DEALER OR RETAILER, WITH RESPECT TO ANY PRODUCT (SUCH AS ANY "EXTENDED WARRANTIES"), SHALL BIND WEBER. THE EXCLUSIVE REMEDY OF THIS WARRANTY IS REPAIR OR REPLACEMENT OF THE PART OR PRODUCT.**

**IN NO EVENT UNDER THIS VOLUNTARY WARRANTY SHALL RECOVERY OF ANY KIND BE GREATER THAN THE AMOUNT OF THE PURCHASE PRICE OF THE WEBER PRODUCT SOLD.**

**YOU ASSUME THE RISK AND LIABILITY FOR LOSS, DAMAGE, OR INJURY TO YOU AND YOUR PROPERTY AND/OR TO OTHERS AND THEIR PROPERTY ARISING OUT OF THE MISUSE OR ABUSE OF THE PRODUCT OR FAILURE TO FOLLOW INSTRUCTIONS PROVIDED BY WEBER IN THE ACCOMPANYING OWNER'S MANUAL.**

**PARTS AND ACCESSORIES REPLACED UNDER THIS WARRANTY ARE WARRANTED ONLY FOR THE BALANCE OF THE ABOVE MENTIONED ORIGINAL WARRANTY PERIOD(S).**

**THIS WARRANTY APPLIES TO PRIVATE SINGLE FAMILY HOME OR APARTMENT USE ONLY AND DOES NOT APPLY TO WEBER BARBECUES USED IN COMMERCIAL, COMMUNAL OR MULTI-UNIT SETTINGS SUCH AS RESTAURANTS, HOTELS, RESORTS, OR RENTAL PROPERTIES.**

**WEBER MAY FROM TIME TO TIME CHANGE THE DESIGN OF ITS PRODUCTS. NOTHING CONTAINED IN THIS WARRANTY SHALL BE CONSTRUED AS OBLIGATING WEBER TO INCORPORATE SUCH DESIGN CHANGES INTO PREVIOUSLY MANUFACTURED PRODUCTS, NOR SHALL SUCH CHANGES BE CONSTRUED AS AN ADMISSION THAT PREVIOUS DESIGNS WERE DEFECTIVE.**

Refer to International Business Units list at the end of this Owner's Manual for additional contact information.

# TABLE OF CONTENTS

- 2 Safety
- 3 Warranty
- 4 Cooking System
- 5 Special Features
- 7 Before Lighting
  - Choose a proper location to barbecue
  - Choose how much charcoal to use
  - The very first time you barbecue
  - Preparing the barbecue for lighting
- 8 Lighting Charcoal
  - Setting up the barbecue for direct cooking method
  - Setting up the barbecue for indirect cooking method
- 10 Barbecuing Methods
  - Direct heat
- 11 Barbecuing Methods
  - Indirect heat
- 12 Cooking Guide
- 13 Barbecuing Methods
  - Smoking
- 14 Smoking Wood Types
- 15 Tips and Tricks for Barbecuing and Smoking Success
- 16 Replacement Parts

Visit [weber.com](http://weber.com), select your country of origin, and register your barbecue today.



# COOKING SYSTEM

Extensive thought was put into how your charcoal barbecue was designed. We design our barbecues to perform so that you never have to worry about flare-ups, hot and cold spots, or burnt food. Expect excellent performance, control, and results every time.

## A Bowl and Lid

Every WEBER charcoal barbecue is made with a baked-on porcelain-enamel coated steel bowl and lid. This is important because it means it will never peel or flake. The reflective surface provides convection cooking, so that the heat radiates around the food much like an indoor oven providing you with even cooking results.

## B Dampers and Vents

A big factor in charcoal barbecuing is air. The more air that you allow into the barbecue, the hotter the internal temperature will be until the fuel has been maximised. During cooking, you can control the internal barbecue temperature by easily adjusting the lid and bowl dampers. To ensure a high internal barbecue temperature for direct method cooking, be sure that the bowl and lid vents are fully open. If your intention is to cook indirectly or smoke foods at lower temperatures, you can close the lid and bowl dampers as much as halfway. Closing the dampers completely will cut off oxygen flow and will eventually extinguish the coals.

## C Cooking Grate

Made of heavy-duty stainless steel, the cooking grate provides ample area to make all of your favourite meals.

## D Charcoal Grate

The charcoal grate has what it takes to withstand the heat of any charcoal fire. Made of heavy-duty steel, this durable grate will not warp or burn through. Additionally, it gives you enough space for direct or indirect cooking, providing you with the flexibility to cook the way you want.

## E ONE-TOUCH Cleaning System

The ONE-TOUCH cleaning system makes clean-up hassle free. As you move the handle back and forth, the three blades in the bowl move ash from the bottom of the barbecue into the ash catcher. These same vents act as a bowl damper, to help bring oxygen up to the fire or to allow you to easily extinguish the fire.

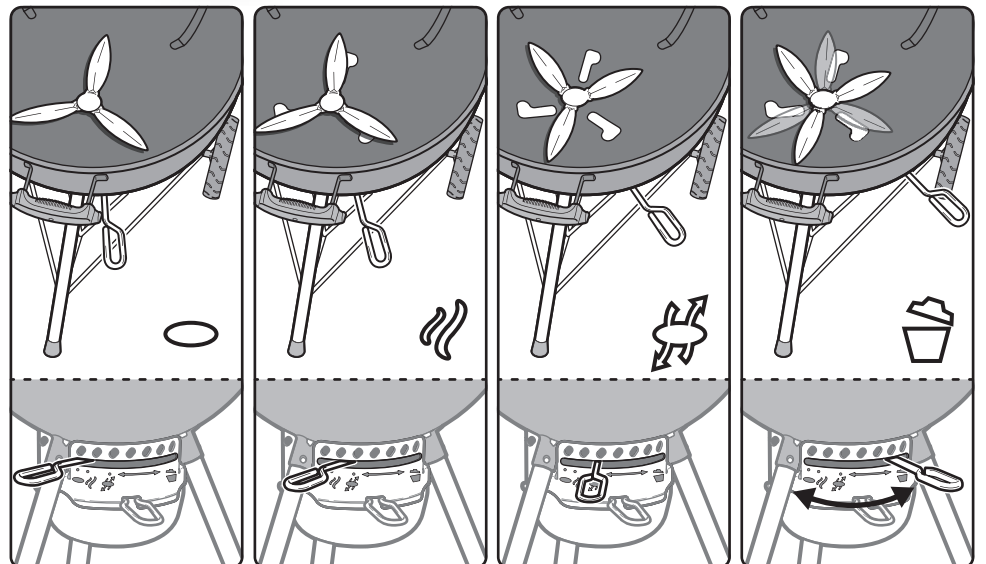
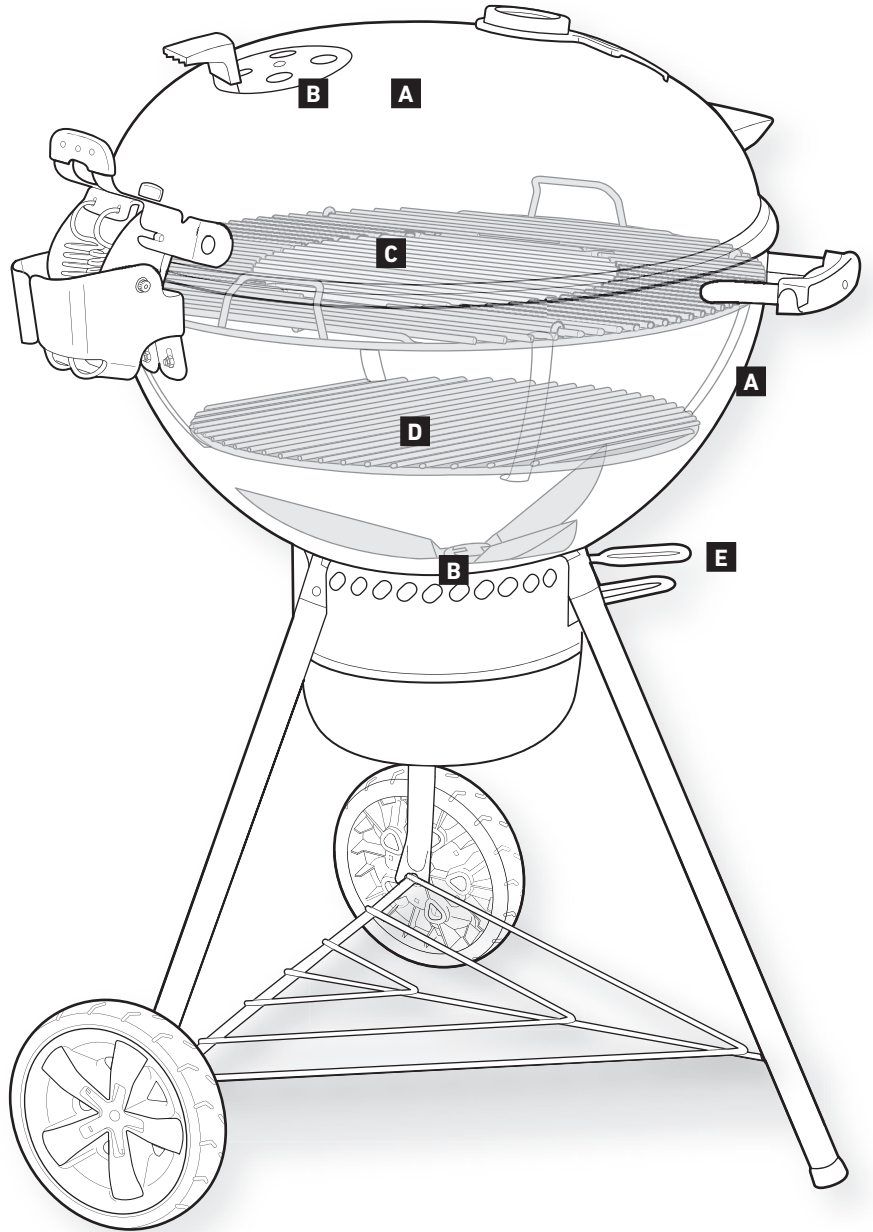



# SPECIAL FEATURES

Depending on the model you purchased, your barbecue may or may not be equipped with the features described.

## A GOURMET BBQ SYSTEM

Your cooking grate is equipped with a special centre area that is removable. This feature is designed to allow you to easily add special GOURMET BBQ SYSTEM cooking inserts such as a sear grate (included with SE E-5775), poultry roaster, or pizza stone (each sold separately). Each option provides you with limitless opportunities to try new recipes. For a full product line of GOURMET BBQ SYSTEM inserts, visit [weber.com](http://weber.com).

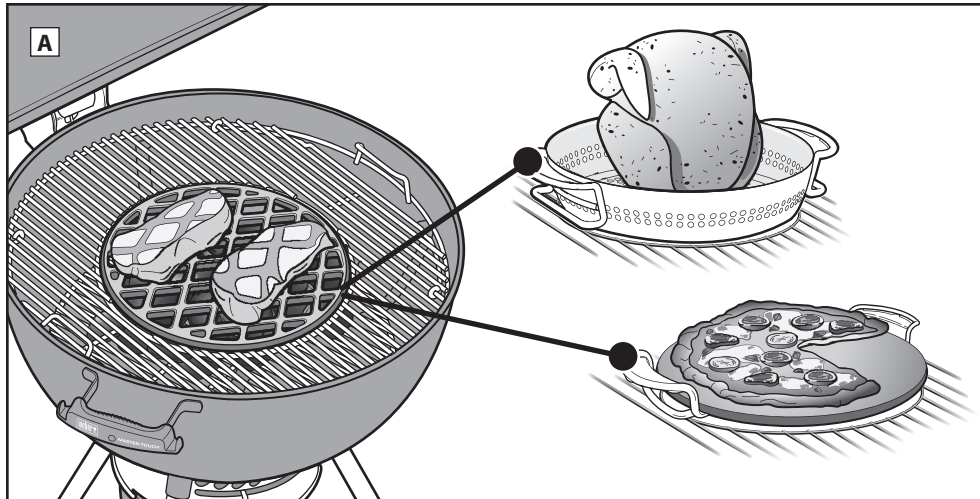

## B Built-In Thermometer

A durable, built-in lid thermometer allows you to easily monitor your barbecue's internal temperature.

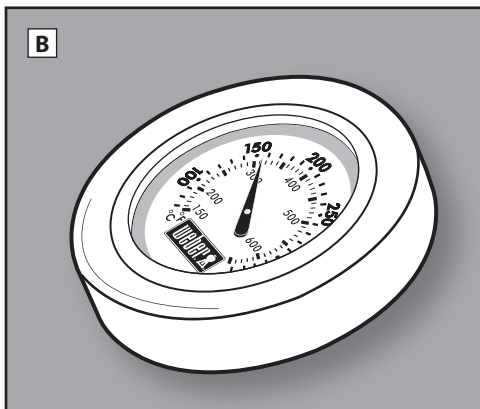

## C Hinged Lid

This newly designed stainless steel lid hinge gives you the convenience of not having to store your lid elsewhere while cooking. The lid is removable from the bowl when using the WEBER rotisserie accessory (sold separately).

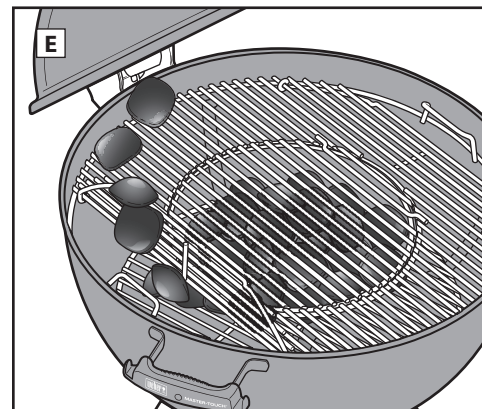

## D iGRILL Bracket

The iGRILL bracket provides a magnetic surface to place your iGRILL MINI or iGRILL 2 (each sold separately) during cooking, as well as storage for up to 4 probes. Remove the iGRILL bracket when not in use.

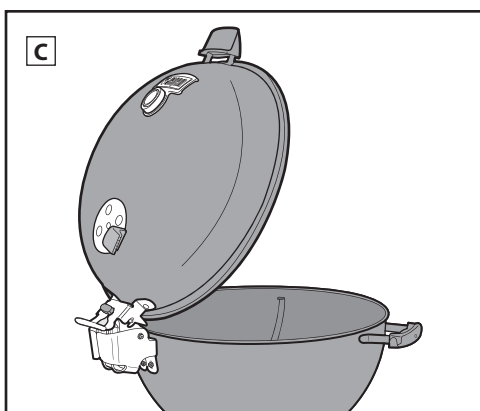

## E Hinged Cooking Grate

The hinged grate has areas on both sides that lift up to allow you to easily add fuel.

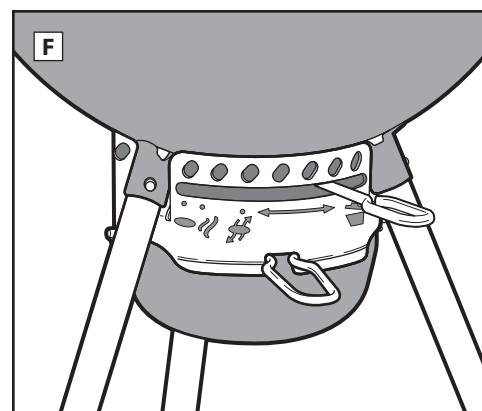

## F High Capacity Ash Catcher

The fully enclosed high capacity ash catcher keeps ashes from blowing around and easily detaches for quick and clean ash removal.

## G Tool Hook Handles

The bowl handle has hooks built right in so you have a convenient place to hang your tools.

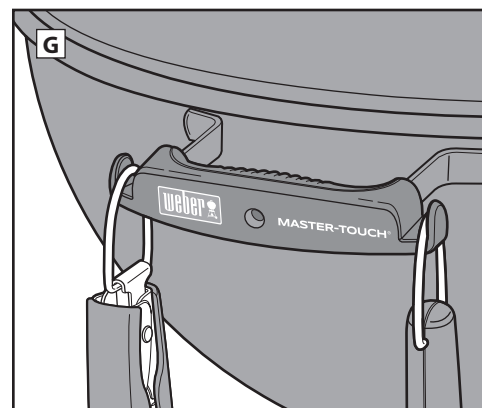
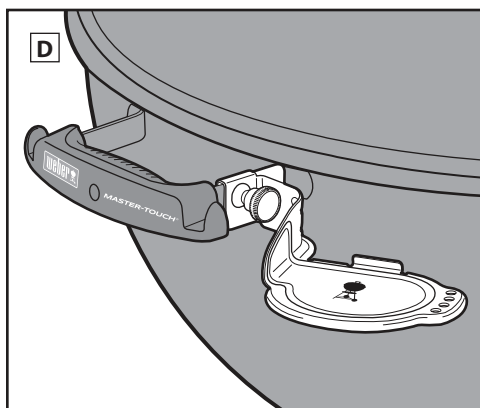



# SPECIAL FEATURES

## **H** Curved Cooking Grate Handles

The curved handles of the cooking grate allow it to hang from the side of the bowl.

## **I** Bowl Vents for Smoking

The new shape of these bowl vents allows the perfect amount of airflow for smoking and low temperature barbecuing.

## **J** Char-Ring & Diffuser Plate

These new tools will help you bring all of the joys of smoking food to your charcoal barbecue by keeping the temperature consistent and low over a longer period of time. We like to refer to this method as "low and slow".

## **K** ONE-TOUCH Cleaning System Handle Cover (SE E-5775 only)

The ONE-TOUCH cleaning system handle cover provides a non-slip grip and minimises heat from the ONE-TOUCH cleaning system handle.

## **L** Lid Damper Touch Point

The lid damper touch point minimises heat from the lid damper for increased comfort.

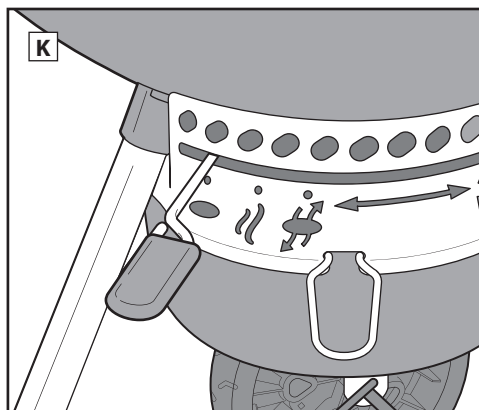
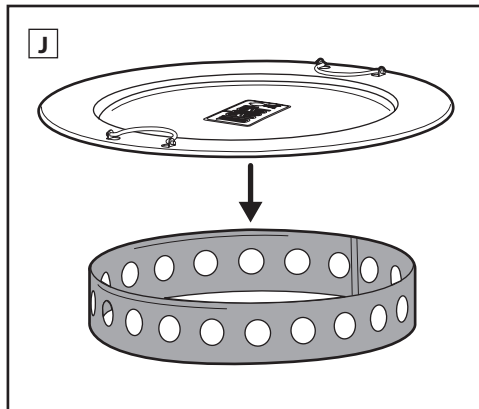
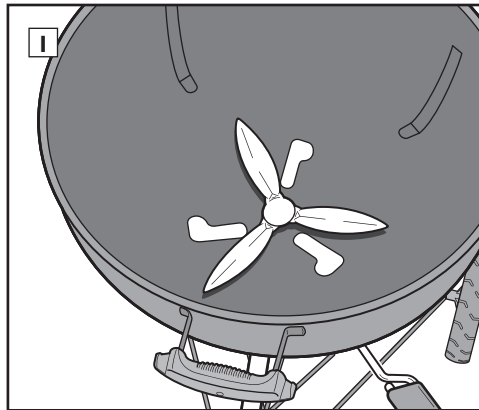
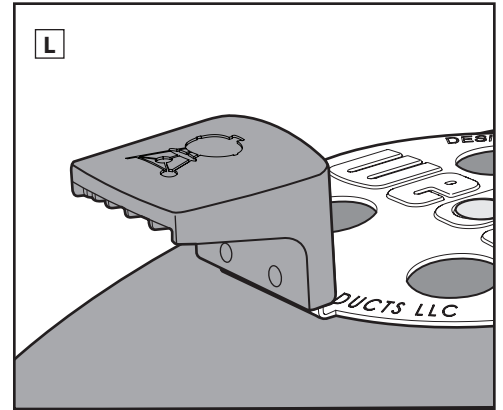
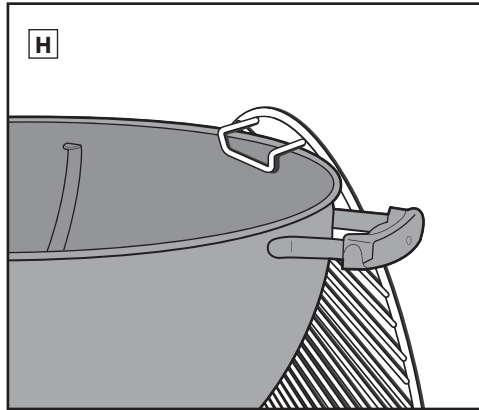



# BEFORE LIGHTING

## Choose a Proper Location to Barbecue

- Only use this barbecue outdoors in a well-ventilated area. Do not use in a garage, building, breezeway, or any other enclosed area.
- Keep the barbecue on a secure, level surface at all times.
- Do not use barbecue within five feet (1.5 m) of any combustible material. Combustible materials include, but are not limited to, wood or treated wood decks, patios, and porches.

## Choose How Much Charcoal to Use

Choosing charcoal quantity depends on what you are barbecuing and the size of your barbecue. If you are barbecuing small, tender pieces of food that take less than 20 minutes, refer to the *Measuring & Adding Charcoal for Direct Heat* chart. If you are barbecuing larger joints of meat that require 20 minutes or more of barbecuing time, or delicate foods, refer to the *Measuring & Adding Charcoal for Indirect Heat* chart. Use the charcoal cup supplied with your barbecue to measure the appropriate amount of charcoal. For more details about the difference between smoking, direct, and indirect cooking, refer to the *BARBECUING METHODS* sections.

## The Very First Time You Barbecue

It is recommended that the barbecue be heated up and the fuel kept red hot, with the lid on, for at least 30 minutes prior to cooking for the first time to burn off any manufacturing residue.

## Preparing the Barbecue for Lighting

1. Lift the lid to the open position.
2. To remove the GOURMET BBQ SYSTEM cooking grate, first remove the detachable centre area, and then the full cooking grate from the barbecue (A). *Note: The curved handles of the cooking grate allow it to hang from the side of the bowl.*
3. Remove the charcoal (bottom) grate and clear ashes or chunks of old charcoal from the bottom of the bowl using the ONE-TOUCH cleaning system. Charcoal requires oxygen to burn, so be sure that nothing clogs the vents. Move the ONE-TOUCH cleaning system handle back and forth to remove ash from the bottom of the barbecue into the ash catcher (B).
4. To remove the high capacity ash catcher and dispose of the ashes, squeeze the ash catcher handle to release it from the barbecue (C).
5. Open the bowl vents by moving the ONE-TOUCH cleaning system handle to the fully open position (D).
6. Replace charcoal (bottom) grate (E).
7. Open the lid vents by moving the lid damper to the fully open position (F).

*Note: Instructions for using lighter fluid were purposely left out of this owner's guide. Lighter fluid is messy and can transmit a chemical taste to your food, while lighter cubes (sold separately) do not. If you choose to use lighter fluid, follow the manufacturer's instructions and NEVER add lighter fluid to a burning fire.*

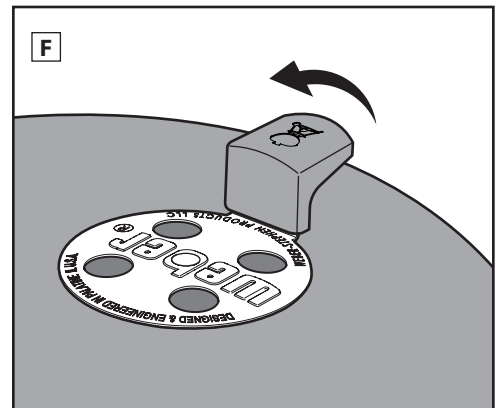
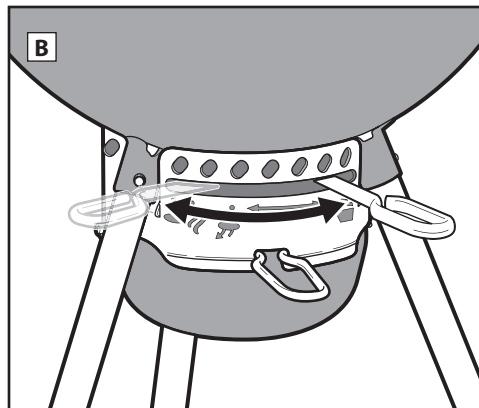
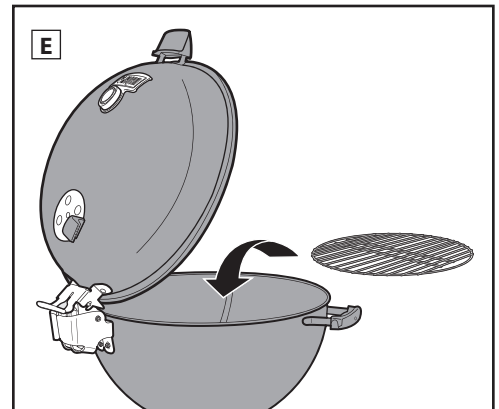
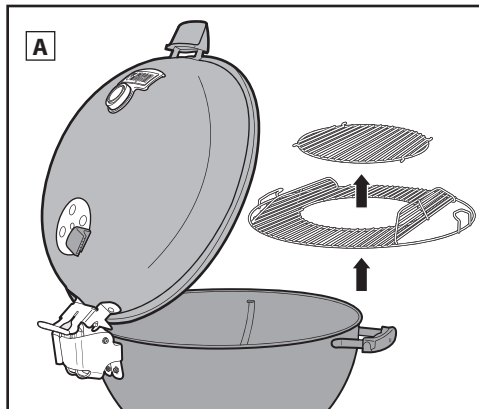
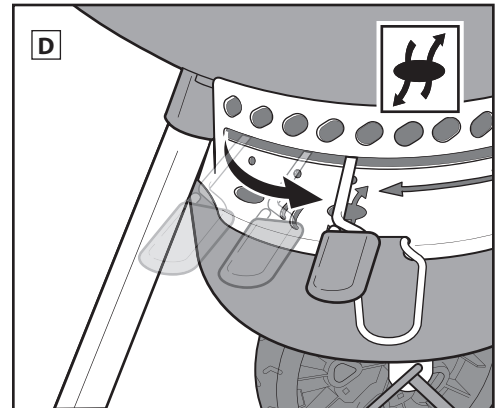
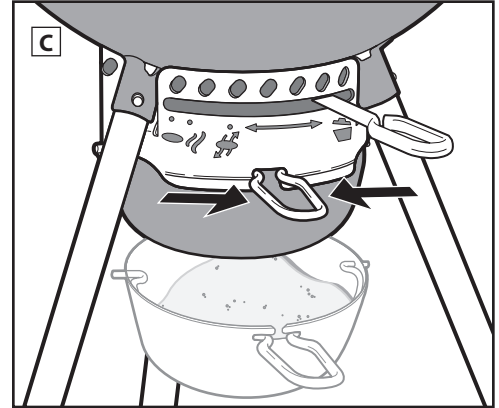



# LIGHTING CHARCOAL

Before lighting charcoal, determine which barbecuing method you will be using.

## Setting Up the Barbecue for Direct Barbecuing Method

### Lighting the Charcoal Using a Chimney Starter

The simplest, most thorough way to light any kind of charcoal is to use a chimney starter; particularly, the WEBER RAPIDFIRE chimney starter (sold separately). Refer to the cautions and warnings included with the RAPIDFIRE chimney starter before lighting the charcoal.

1. Put a few sheets of crumpled up newspaper in the bottom of the chimney starter and set the chimney starter on the charcoal (bottom) grate (A); or put a few lighter cubes in the centre of the charcoal grate and place the chimney starter over them (B).
2. Fill the chimney starter with charcoal (C).
3. Using a long lighter or matchstick, light the lighter cubes or newspaper through the holes on the bottom side of the chimney starter (D).
4. Keep the chimney starter in place until the charcoal is fully lit. You know the charcoal is fully lit when it is covered with a coating of white ash.

*Note: Lighter cubes must be completely consumed and the charcoal ashed over before placing food on the cooking grate. Do not cook before the charcoal has a coating of ash.*

5. Once the charcoal is fully lit, continue to the following pages for instructions on how to arrange your charcoal and begin cooking according to your desired barbecuing method.

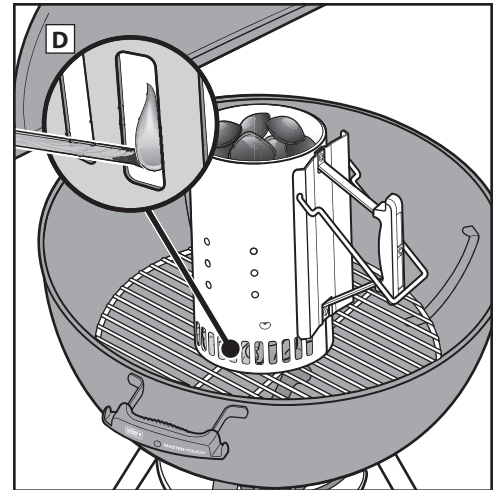
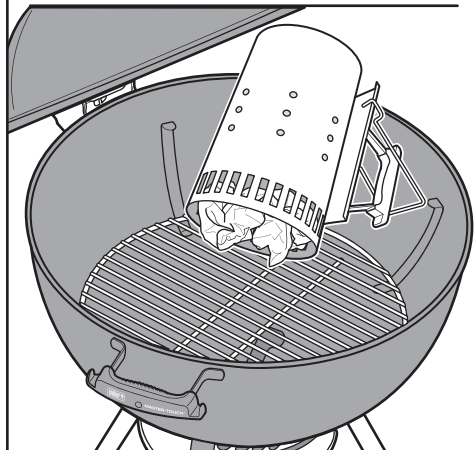
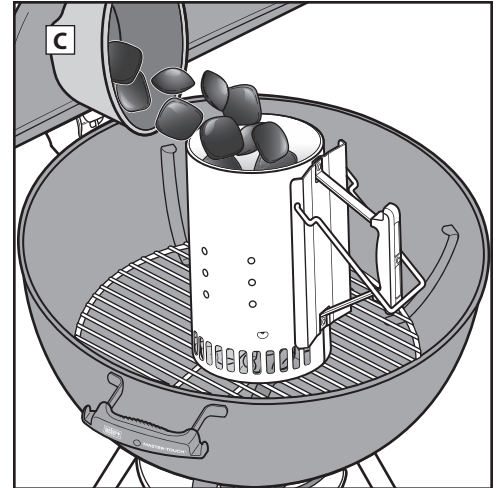
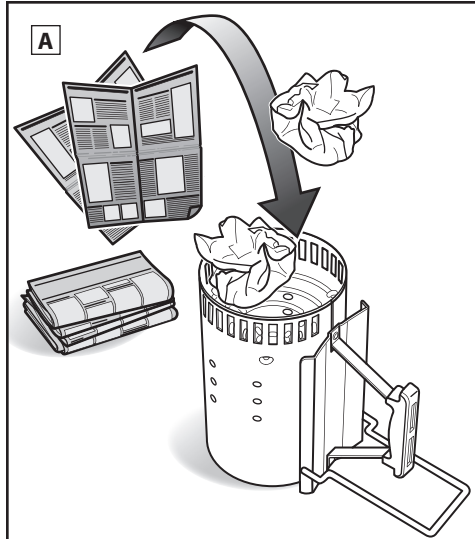

### Lighting the Charcoal Without a Chimney Starter

1. Build a pyramid of charcoal in the centre of the charcoal (bottom) grate and insert a couple of lighter cubes (sold separately) within the pyramid.
2. Using a long lighter or matchstick, light the lighter cubes. The lighter cubes will then ignite the charcoal (E).
3. Wait for the charcoal to fully light. You know the charcoal is fully lit when it is covered with a coating of white ash.

*Note: Lighter cubes must be completely consumed and the charcoal ashed over before placing food on the cooking grate. Do not cook before the charcoal has a coating of ash.*

4. Once the charcoal is fully lit, continue to the following pages for instructions on how to arrange your charcoal and begin cooking according to your desired barbecuing method.

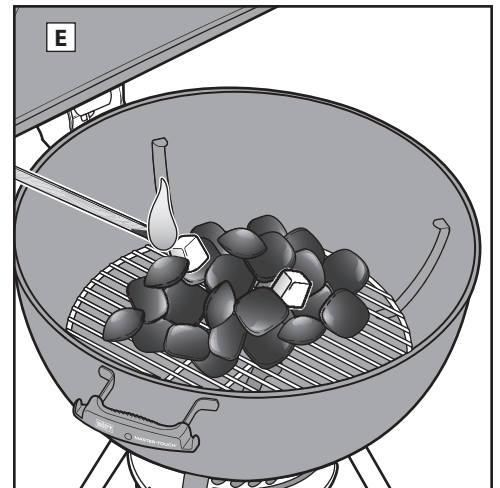
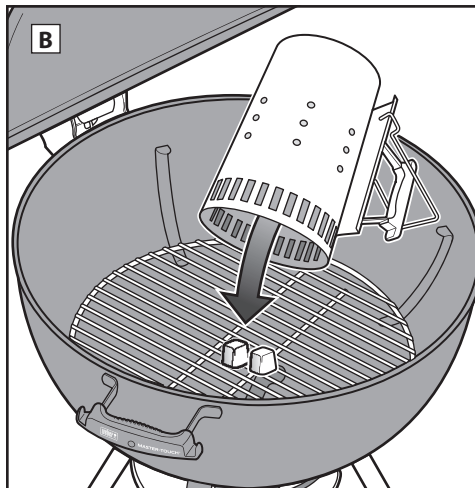





# LIGHTING CHARCOAL

## Setting Up the Barbecue for Indirect Barbecuing Method

When using the indirect barbecuing method, you have the option to spread the coals directly on the charcoal (bottom) grate on opposite sides of the bowl, or make use of the WEBER CHAR-BASKETS.

⚠ **Avoid positioning charcoal next to the lid and bowl handles or directly beneath the thermometer and lid damper.**

⚠ **When using the CHAR-BASKETS, they must first be placed into the bowl of the barbecue on the charcoal (bottom) grate before lighting the charcoal.**

## Lighting the Charcoal Using a Chimney Starter

The simplest, most thorough way to light any kind of charcoal is to use a chimney starter; particularly, the WEBER RAPIDFIRE chimney starter (sold separately). Refer to the cautions and warnings included with the RAPIDFIRE chimney starter before lighting the charcoal.

1. Put a few sheets of crumpled up newspaper in the bottom of the chimney starter and set the chimney starter on the charcoal (bottom) grate between the CHAR-BASKETS if they are being used (F); or put a few lighter cubes in the centre of the charcoal (bottom) grate and place the chimney starter over them (G).
2. Fill the chimney starter with charcoal (H).
3. Using a long lighter or matchstick, light the lighter cubes or newspaper through the holes on the bottom side of the chimney starter (I).
4. Keep the chimney starter in place until the charcoal is fully lit. You know the charcoal is fully lit when it is covered with a coating of white ash.

*Note: Lighter cubes must be completely consumed and the charcoal ashed over before placing food on the cooking grate. Do not cook before the charcoal has a coating of ash.*

5. Once the charcoal is fully lit, continue to the following pages for instructions on how to arrange your charcoal and begin cooking according to your desired barbecuing method.

## Lighting the Charcoal Without a Chimney Starter

⚠ **Avoid positioning charcoal next to the lid and bowl handles or directly beneath the thermometer and lid damper.**

⚠ **When using the CHAR-BASKETS, they must first be placed into the bowl of the barbecue before lighting the charcoal.**

1. Place CHAR-BASKETS on the charcoal (bottom) grate on opposite sides of the bowl.
2. Fill each CHAR-BASKET with your choice of charcoal (J).
3. Insert a couple of lighter cubes (sold separately) within the charcoal.

*Note: Be sure to slightly bury them at the top of the charcoal briquettes.*

4. Using a long lighter or matchstick, light the lighter cubes (K). The lighter cubes will then ignite the charcoal.

5. Wait for the charcoal to fully light. You know the charcoal is fully lit when it is covered with a coating of white ash.

*Note: Lighter cubes must be completely consumed and the charcoal ashed over before placing food on the cooking grate. Do not cook before the charcoal has a coating of ash.*

6. Once the charcoal is fully lit, continue to the following pages for instructions on how to arrange your charcoal and begin cooking according to your desired barbecuing method.

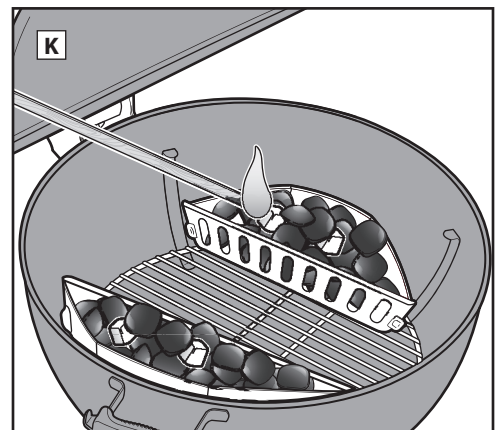
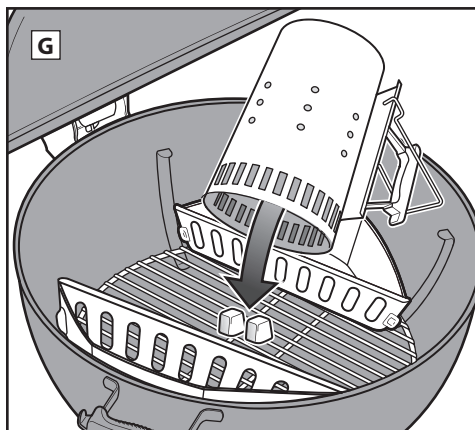
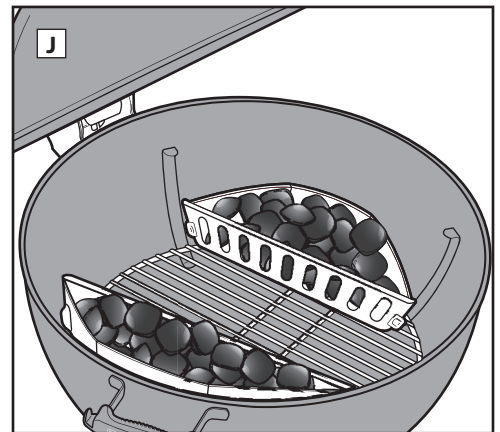
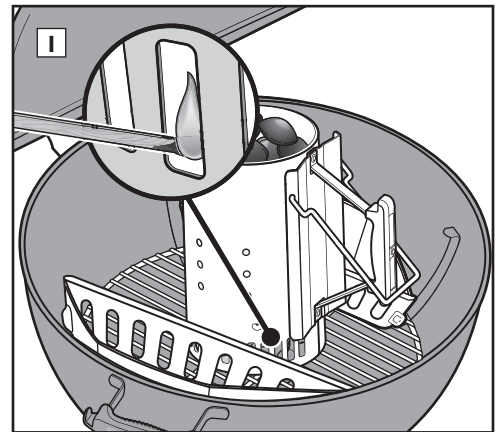
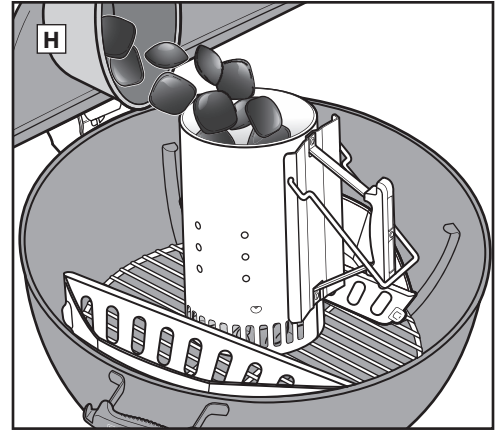
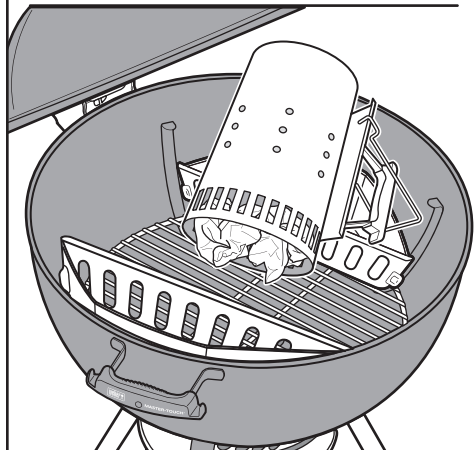
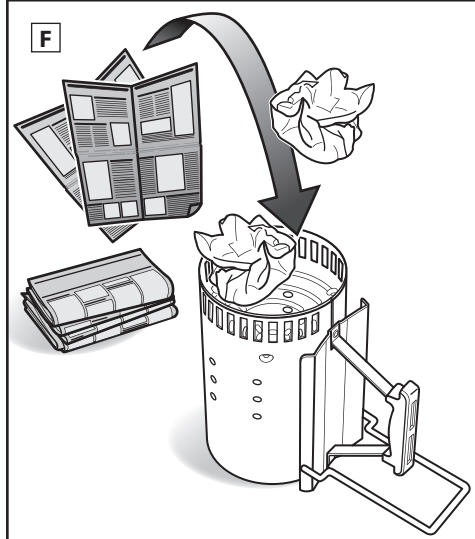



# BARBECUING METHODS - DIRECT HEAT

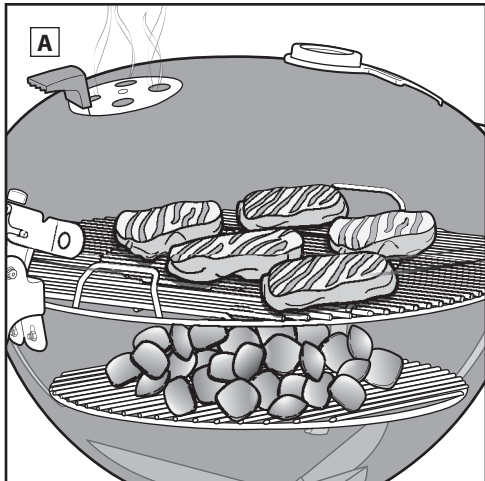

## Barbecuing With Direct Heat

Use the direct method for small, tender pieces of food that take less than 20 minutes to cook, such as:

- Hamburgers
- Steaks
- Chops
- Kebabs/ Skewers
- Boneless chicken pieces
- Fish fillets
- Shellfish
- Sliced vegetables

With direct heat, the fire is right below the food (A). It sears or browns the surfaces of the food, developing flavours, texture, and delicious caramelisation while it also cooks the food all the way to the centre.

A direct fire creates both radiant and conductive heat. Radiant heat from the charcoal quickly cooks the surface of the food closest to it. At the same time, the fire heats the cooking grate rods, which conduct heat directly to the surface of the food and create those unmistakable and lovely barbecue marks.

## Arranging the Charcoal for Direct Heat

1. Always wear barbecue mitts or gloves conforming to EN 407 (Contact Heat rating level 2 or greater) when using your charcoal barbecue.  
*Note: The barbecue, including the handles and damper/vent handles, will become hot. Make sure that you are wearing barbecue mitts or gloves to avoid burning your hands.*
2. When the charcoal is fully lit, using barbecue mitts or gloves and long handle tongs, spread the charcoal evenly across the charcoal (bottom) grate with a charcoal rake or long tongs (B).
3. Make sure the ONE-TOUCH cleaning system handle and lid damper are in the fully open position (C), (D).
4. Once the charcoal has ashed over, replace the cooking grate inside the bowl.
5. Close the lid on the barbecue.
6. Preheat the cooking grate for approximately 10 to 15 minutes.
7. Once the cooking grate is preheated, open the lid. Using a barbecue brush, scrub the cooking grate clean (E).
- Note: When using a stainless steel bristle barbecue brush, replace the brush if any loose bristles are found on the cooking grate or brush.*
8. Place your food on the cooking grate.
9. Close the lid on the barbecue. Consult recipe for recommended cooking times.

### When finished cooking...

Close the lid damper and bowl vents to extinguish the charcoal (F).

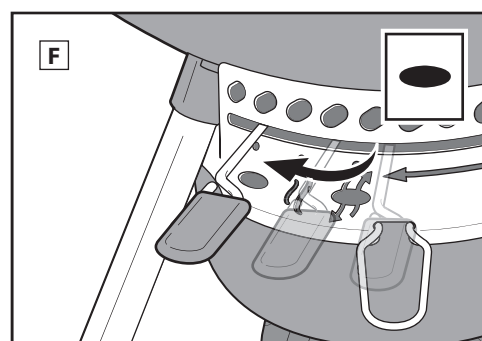
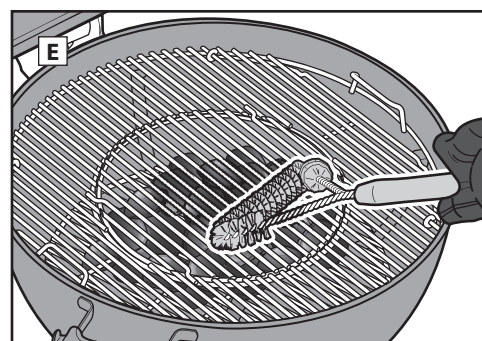
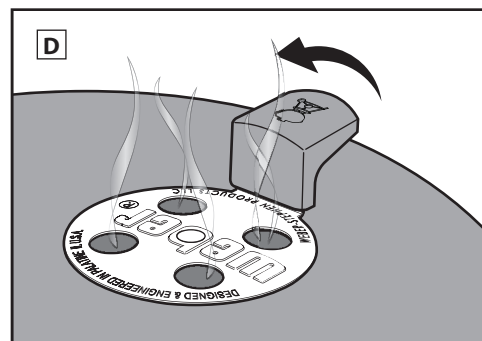
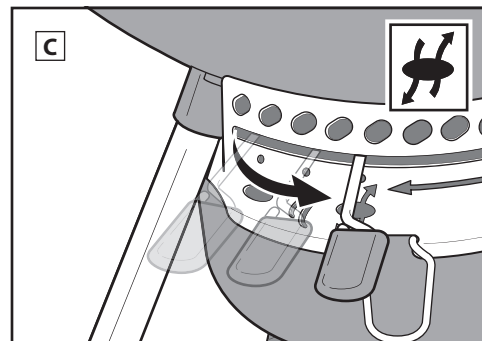
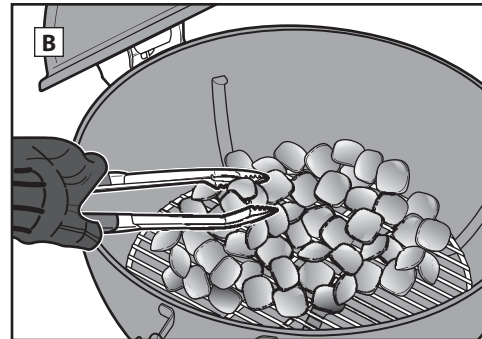

## Measuring & Adding Charcoal for Direct Heat

\*When measuring lump charcoal, use the charcoal measuring cup provided with your barbecue.

Barbecue Diameter	WEBER Charcoal Briquettes	Charcoal Briquettes	Beech wood Lump Charcoal*	Mixed Wood Lump Charcoal*
57 cm	30 briquettes	40 briquettes	1 ¾ cups (0.98 kg)	1 ¾ cups



# BARBECUING METHODS - INDIRECT HEAT

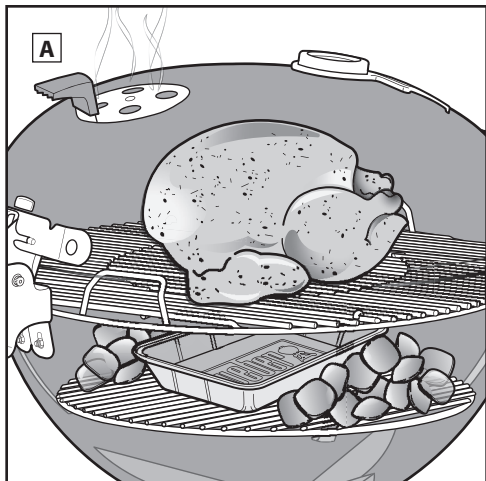

## Barbecuing With Indirect Heat

Use the indirect method for larger cuts of meat that require 20 minutes or more of barbecuing time, or for foods so delicate that direct exposure to the heat would dry them out or scorch them, such as:

- Joints
- Bone-in poultry pieces
- Whole fish
- Delicate fish fillets
- Whole chickens
- Turkeys
- Ribs

Indirect heat can also be used for finishing thicker foods or bone-in cuts that have been seared or browned first over direct heat.

With indirect heat, the heat is on both sides of the barbecue, or off to one side of the barbecue. The food sits on the portion of the cooking grate without charcoal directly below it (A).

The radiant and conductive heat are still factors, but they are not as intense while indirect cooking. However, if the lid of the barbecue is closed, as it should be, there is another kind of heat generated: convection heat. Heat rises, reflects off the lid and inside surfaces of the barbecue, and circulates to slowly cook the food evenly on all sides.

Convection heat doesn't sear or brown the surface of the food the way radiant and conductive heat do. It cooks it more gently all the way to the centre, like the heat in an oven.

## Arranging the Charcoal for Indirect Heat

1. Always wear barbecue mitts or gloves conforming to EN 407 (Contact Heat rating level 2 or greater) when using your charcoal barbecue.

*Note: The barbecue, including the handles and damper/vent handles, will become hot. Make sure that you are wearing barbecue mitts or gloves to avoid burning your hands.*

2. Once the charcoal is fully lit using your preferred indirect barbecuing method (refer to "Lighting Charcoal" section), using barbecue mitts or gloves and long handle tongs, be sure that the charcoal is properly positioned on opposite sides of the bowl. Avoid positioning the charcoal next to the lid and bowl handles, or directly beneath the thermometer and lid damper (B). A drip pan may be placed between the charcoal to collect food drippings.

3. Make sure the ONE-TOUCH cleaning system handle and lid damper are in the fully open position (C), (D).

4. Once the charcoal has ashed over, replace the cooking grate inside the bowl. Make sure that the hinged sides of the cooking grate are directly above the charcoal inside the bowl.

5. Close the lid on the barbecue.

6. Preheat the grate for approximately 10 to 15 minutes.

7. Once the cooking grate is preheated, open the lid. Using a barbecue brush, scrub the cooking grate clean (E).

*Note: When using a stainless steel bristle barbecue brush, replace the brush if any loose bristles are found on the cooking grate or brush.*

8. Place your food in the centre of the cooking grate, above a drip pan if using one.

9. Close the lid on the barbecue. Always position the lid so that the thermometer is not above the charcoal where it will be exposed to direct heat. Adjust the lid and bowl dampers to lower the interior barbecue temperature if necessary. Consult recipe for recommended cooking times.

*Note: Rotate the lid damper fully open to raise the temperature and close it more to lower the temperature.*

### When finished cooking...

Close the lid damper and bowl vents to extinguish the charcoal (F).

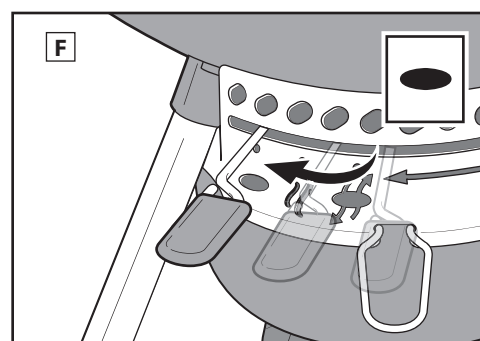
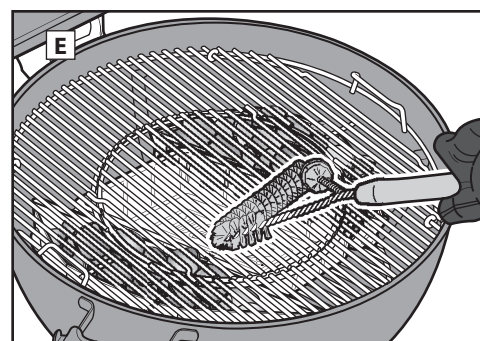
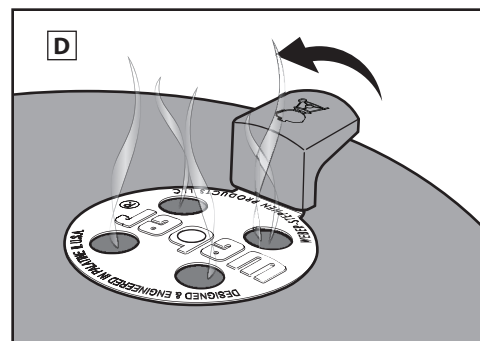
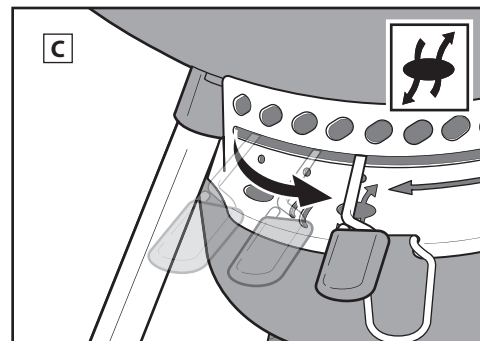
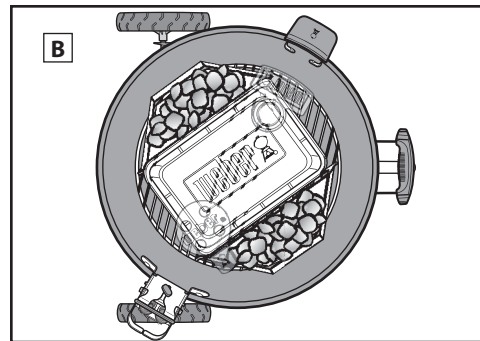

## Measuring & Adding Charcoal for Indirect Heat

\*When measuring lump charcoal, use the charcoal measuring cup provided with your barbecue.

Barbecue Diameter	WEBER Charcoal Briquettes		Charcoal Briquettes		Beech wood Lump Charcoal*		Mixed Wood Lump Charcoal*	
	Briquettes for first hour (per side)	Briquettes to add for each additional hour (per side)	Briquettes for first hour (per side)	Briquettes to add for each additional hour (per side)	Charcoal for first hour (per side)	Charcoal to add for each additional hour (per side)	Charcoal for first hour (per side)	Charcoal to add for each additional hour (per side)
57 cm	15 briquettes	4 briquettes	20 briquettes	7 briquettes	½ cup	1 handful	½ cup	1 handful



Cooking times for beef and lamb use the United States Department of Agriculture definition of medium doneness, unless otherwise noted. The cuts, thicknesses, weights and barbecuing times are meant to be guidelines. Factors such as altitude, wind and outside temperature can affect cooking times.

Visit [weber.com](http://weber.com) for recipes and barbecuing tips.

	Thickness/Weight	Approximate Total Barbecuing Time	
RED MEAT	<b>Steak:</b> New York strip, porterhouse, rib-eye, T-bone, and filet mignon (tenderloin)	2cm thick 2.5cm thick 5cm thick	<b>4 to 6 minutes</b> direct high heat <b>6 to 8 minutes</b> direct high heat <b>14 to 18 minutes</b> brown 6 to 8 minutes direct high heat, and barbecue 8 to 10 minutes indirect high heat
	<b>Flank Steak</b>	0.7kg to 1kg, 2cm thick	<b>8 to 10 minutes</b> direct medium heat
	<b>Minced Beef Patty</b>	2cm thick	<b>8 to 10 minutes</b> direct medium heat
	<b>Tenderloin</b>	1.4 to 1.8kg	<b>45 to 60 minutes</b> 15 minutes direct medium heat, and barbecue 30 to 45 minutes indirect medium heat
	<b>Bratwurst: fresh</b>	85g link	<b>20 to 25 minutes</b> direct low heat
PORK	<b>Chop:</b> boneless or bone-in	2cm thick 3 to 4cm thick	<b>6 to 8 minutes</b> direct high heat <b>10 to 12 minutes</b> brown 6 minutes direct high heat, and barbecue 4 to 6 minutes indirect high heat
	<b>Ribs:</b> baby back, spareribs	1.4 to 1.8kg	<b>1½ to 2 hours</b> indirect medium heat
	<b>Ribs:</b> country-style, bone-in	1.4 to 1.8kg	<b>1½ to 2 hours</b> indirect medium heat
	<b>Tenderloin</b>	0.5kg	<b>30 minutes</b> brown 5 minutes direct high heat, and barbecue 25 minutes indirect medium heat
	<b>Chicken Breast:</b> boneless, skinless	170 to 227g	<b>8 to 12 minutes</b> direct medium heat
POULTRY	<b>Chicken Thigh:</b> boneless, skinless	113g	<b>8 to 10 minutes</b> direct medium heat
	<b>Chicken Pieces:</b> bone-in, assorted	85 to 170g	<b>36 to 40 minutes</b> 6 to 10 minutes direct low heat, 30 minutes indirect medium heat
	<b>Chicken:</b> whole	1.8 to 2.25kg	<b>1 to 1¼ hours</b> indirect medium heat
	<b>Cornish Game Hen</b>	0.7 to 0.9kg	<b>60 to 70 minutes</b> indirect medium heat
	<b>Turkey:</b> whole, unstuffed	4.5 to 5.5kg	<b>2 to 2½ hours</b> indirect medium heat
	<b>Fish, Fillet, or Steak:</b> halibut, red snapper, salmon, sea bass, swordfish, tuna	0.6 to 1.25cm thick 2.5 to 3cm thick	<b>3 to 5 minutes</b> direct medium heat <b>10 to 12 minutes</b> direct medium heat
SEAFOOD	<b>Fish:</b> whole	0.5kg 1.4kg	<b>15 to 20 minutes</b> indirect medium heat <b>30 to 45 minutes</b> indirect medium heat
	<b>Shrimp</b>	14g	<b>2 to 4 minutes</b> direct high heat
	<b>Asparagus</b>	1.25cm diameter	<b>6 to 8 minutes</b> direct medium heat
VEGETABLES	<b>Corn</b>	in husk husked	<b>25 to 30 minutes</b> direct medium heat <b>10 to 15 minutes</b> direct medium heat
	<b>Mushroom</b>	shiitake or button portobello	<b>8 to 10 minutes</b> direct medium heat <b>10 to 15 minutes</b> direct medium heat
	<b>Onion</b>	halved 1.25cm slices	<b>35 to 40 minutes</b> indirect medium heat <b>8 to 12 minutes</b> direct medium heat
	<b>Potato</b>	whole 1.25cm slices	<b>45 to 60 minutes</b> indirect medium heat <b>9 to 11 minutes</b> parboil 3 minutes, and barbecue 6 to 8 minutes direct medium heat

Make sure food fits on the barbecue with the lid down, leaving approximately 2.5cm of clearance between the food and lid.

## Cooking Tips

- Barbecue steaks, fish fillets, boneless chicken pieces, and vegetables using the direct method for the time given on the chart (or to the desired doneness) turning food once, halfway through barbecuing time.
- Barbecue roasts, whole poultry, bone-in poultry pieces, whole fish, and thicker cuts using the indirect method for the time given on the chart (or until an instant-read thermometer registers the desired internal temperature).
- Before carving let roasts, larger joints of meat, thick chops and steaks rest for 5 to 10 minutes after cooking. The internal temperature of the meat will rise 5 to 10 degrees during this time.
- For additional smoke flavour, consider adding hardwood chips or chunks (soaked in water for at least 30 minutes and drained) or moistened fresh herbs such as rosemary, thyme, or bay leaves. Place the wet wood or herbs directly on the coals just before you begin cooking.
- Thaw food before barbecuing. Otherwise, allow for a longer cooking time if cooking frozen food.

## Food Safety Tips

- Do not defrost meat, fish, or poultry at room temperature. Defrost in the refrigerator.
- Wash your hands thoroughly with hot, soapy water before starting any meal preparation and after handling fresh meat, fish, and poultry.
- Never place cooked food on the same plate raw food was on.
- Wash all plates and cooking utensils that have come into contact with raw meat or fish with hot, soapy water and rinse.



# BARBECUING METHODS - SMOKING

## Smoking

Smoking is cooking food at a low temperature over an extended period of time using various hardwood chunks or chips. This technique is also referred to as the "low and slow" method. Cooking low and slow helps keep the juices in your food to produce an extremely tender piece of meat and infuse delicate smoky flavour. Smoking works great for cuts of meat such as:

- Whole Turkey
- Ribs
- Whole Chicken
- Pork Shoulder
- Duck
- Sausages

Just like with indirect cooking, convection heat plays an important role when smoking food. With convection heat, the heat rises, reflects off of the lid and inside surfaces of the barbecue, and circulates to slowly cook the food evenly on all sides. Convection heat doesn't sear or brown the surface of the food the way that radiant and conductive heat do. Convection heat cooks the food gently all the way to the centre similar to the way an oven cooks.

## Barbecue Setup for Smoking

1. Always wear barbecue mitts or gloves conforming to EN 407 (Contact Heat rating level 2 or greater) when using your charcoal barbecue.

*Note: The barbecue, including the handles and damper/vent handles, will become hot. Make sure that you are wearing barbecue mitts or gloves to avoid burning your hands.*

2. With the charcoal grate in the bottom position of the bowl, place the smoker ring centred on top of the charcoal grate (A).
3. Fill the char ring with approximately 45-50 charcoal briquettes. Spread the charcoal briquettes so they are even with or just below the top of the char ring (B).

*Note: Do not over fill the char ring. Make sure the diffuser plate sits flat on top of the char ring. Remove briquettes as needed before igniting.*

4. Move the ONE-TOUCH cleaning system handle to the fully open position (C).
5. Place 3 WEBER lighter cubes in the centre of the charcoal, and light with a long neck lighter or matches (D). By lighting the charcoal in the centre, the coals will burn slowly from the inside to the outer edge and evenly ignite over the course of your cooking time. The coals are ready once grey ash is beginning to form on top of the centre coals (usually 15-20 minutes).
6. Using barbecue mitts or gloves and long tongs, add 2 to 4 WEBER wood chunks or a handful of WEBER wood chips around the perimeter of the lit charcoal (E).

See the **SMOKING WOOD TYPES** chart following this section for more information.

*Note: Wood chips can be pre-soaked in water before use to extend the amount of time they produce smoke.*

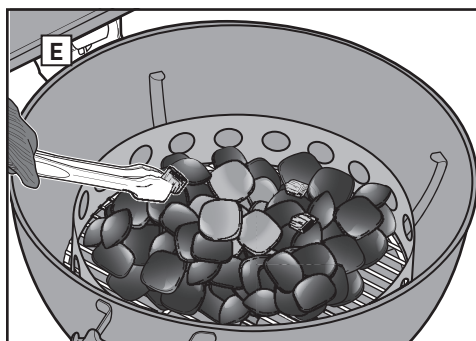
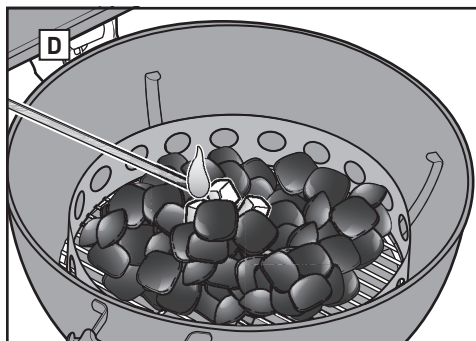
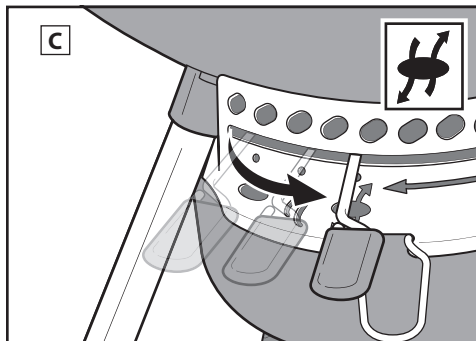
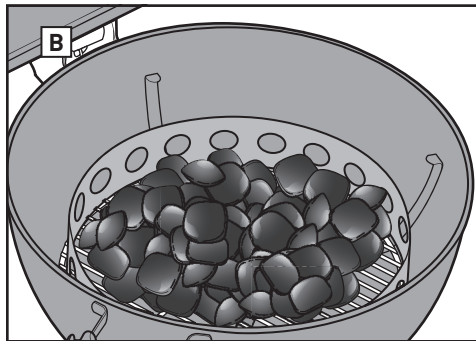
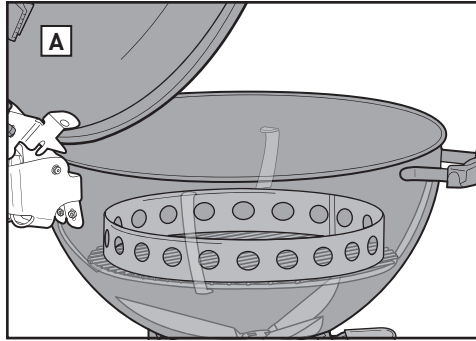

## Charcoal Ring Capacity for Smoking

\*When measuring lump charcoal, use the charcoal measuring cup provided with your barbecue.

Barbecue Diameter	WEBER Charcoal Briquettes
	Briquettes qty. for 6-8 hours cooking time
57 cm	45-50 briquettes



# BARBECUING METHODS - SMOKING

7. Place the diffuser plate centred on top of the smoker ring (F). Be sure that the heat diffuser plate is lying flat and level on top of the smoker ring. Keep the lid open until the charcoal has ashed over.

*Note: A disposable drip pan should be placed on top of the diffuser plate to collect food drippings and minimise cleaning time. Liquids can be added to the disposable drip pan to help moderate the temperature and infuse moisture and flavour into your food.*

8. Place the cooking grate in the top position of the bowl and close the lid for 15 minutes to preheat. Once the barbecue is preheated, open the lid and brush the cooking grate clean (G). Put the food on the centre of the cooking grate, over the drip pan.

9. Close the lid and move the ONE-TOUCH cleaning system handle to the smoking position (H).

10. Once the barbecue temperature reaches the "smoke zone" between 95 and 135°C (200 and 275°F) on the lid thermometer (I), rotate the lid damper accordingly to maintain the ideal smoking temperature range (J).

*Note: Rotate the lid damper fully open to raise the temperature and close it more to lower the temperature.*

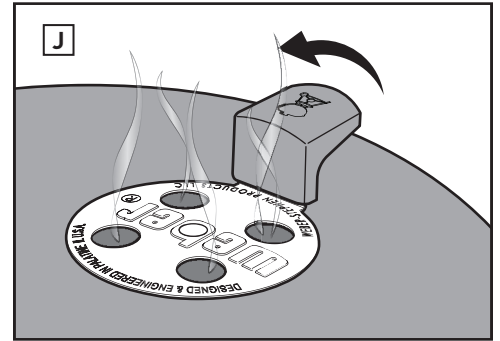
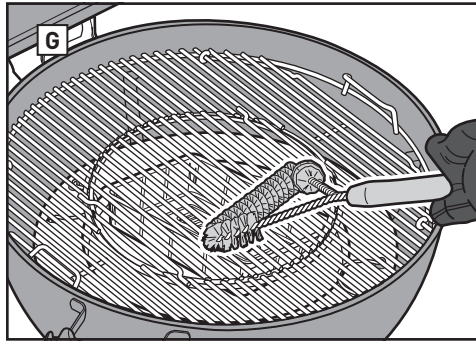
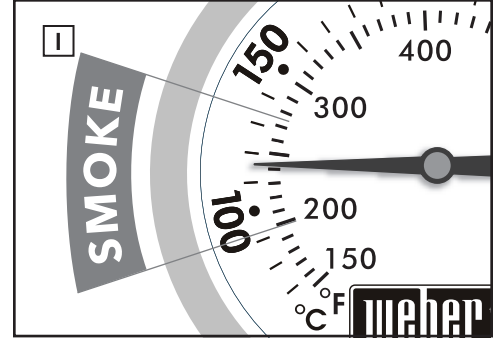
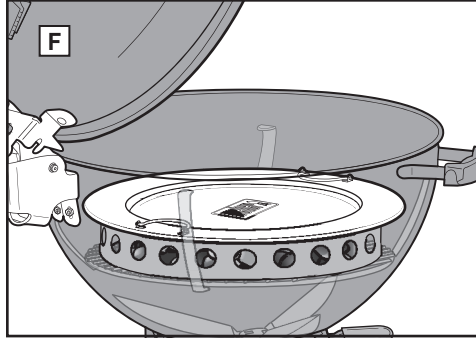

## When finished cooking...

Close the lid damper and bowl vents to extinguish the charcoal.

Cooking times are affected by such factors as altitude, wind, outside temperature, and desired doneness. Smoking is truly an adventure. Experiment with various temperatures, woods, and meats. Write down ingredients, wood amounts, combinations, and results so you can repeat successes.

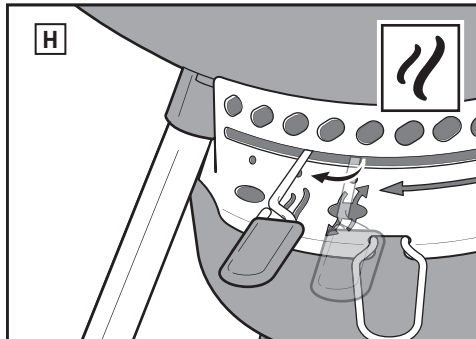

# SMOKING WOOD TYPES

Different hardwoods will impart a variety of flavours. It is best to do some experimenting to find the type of hardwood, or combination of hardwoods, that you like best. Start with the lowest amount of wood chunks; more can be added to suit your own taste.

Experiment with different varieties of wood and amounts used. You can also add bay leaves, garlic cloves, mint leaves, orange or lemon peel and various spices to charcoal for added flavour. Keep a record of your experiments; it's easy to forget what you did last time.

WOOD TYPE	CHARACTERISTICS	FOOD MATCHES
Hickory	Pungent, smoky, bacon-like flavour.	Pork, chicken, beef, wild game, cheeses.
Pecan	Rich and more subtle than hickory, but similar in taste. Burns cool, so ideal for very low heat smoking.	Pork, chicken, lamb, fish, cheeses.
Mesquite	Sweeter, more delicate flavour than hickory. Tends to burn hot, so use carefully.	Most meats, especially beef. Most vegetables.
Alder	Delicate flavour that enhances lighter meats.	Salmon, swordfish, sturgeon, other fish. Also good with chicken and pork.
Maple	Mildly smoky, somewhat sweet flavour.	Poultry, vegetables, ham. Try mixing maple with corncobs for ham or bacon.
Cherry	Slightly sweet, fruity smoke flavour.	Poultry, game birds, pork.
Apple	Slightly sweet but denser, fruity smoke flavour.	Beef, poultry, game birds, pork (particularly ham).

Always avoid soft, resinous woods like pine, cedar, and aspen. ⚠ **WARNING: Never use wood that has been treated or exposed to chemicals.**



## Wear Gloves

Always wear barbecue mitts or gloves conforming to EN 407 (Contact Heat rating level 2 or greater) when using your charcoal barbecue. Vents, dampers, handles, and the bowl will all get hot during the barbecuing process, so be sure to keep your hands and forearms protected.

## Skip the Lighter Fluid

Avoid using lighter fluid, as it can impart a chemical taste to your food. Chimney starters (sold separately) and lighter cubes (sold separately) are much cleaner and much more effective ways of lighting charcoal.

## Preheat the Barbecue

Preheating your barbecue with the lid closed for 10 to 15 minutes prepares the cooking grate. With all of the charcoal glowing red, the temperature under the lid should reach 260°C (500°F). The heat loosens any bits and pieces of food hanging onto the grate, making it easy to brush them off with a stainless steel bristle barbecue brush. Preheating your barbecue gets the grate hot enough to sear or brown properly and also helps prevent food from sticking to the grate.

*Note: Use a stainless steel bristle barbecue brush. Replace brush if any loose bristles are found on the cooking grate or brush.*

## Oil the Food, Not the Grate

Oil prevents food from sticking and also adds flavour and moisture. Lightly brushing or spraying the food with oil works better than brushing the grate.

## Keep the Air Flowing

A charcoal fire needs air. The lid should be closed as much as possible, but keep the lid damper and bowl vent open. Remove the ashes on the bottom of the barbecue regularly to prevent them from blocking the vents.

## Put a Lid on It

For four important reasons, the lid should be closed as much as possible.

1. Keeps the grate hot enough to sear or brown the food.
2. Speeds up the cooking time and prevents the food from drying out.
3. Traps the smokiness that develops when fat and juices vaporise in the barbecue.
4. Prevents flare-ups by limiting oxygen.

## Tame the Flame

Flare-ups happen, which is good because they sear or brown the surface of what you are barbecuing; however, too many flare-ups can burn your food. Keep the lid on as much as possible. This limits the amount of oxygen inside the barbecue, which will help extinguish any flare-ups. If the flames are getting out of control, move the food over indirect heat temporarily, until they die down.

## Watch the Time and Temperature

If you are barbecuing in a colder climate or in a higher altitude, the cooking times will be longer. If the wind is blowing hard, it will raise a charcoal barbecue's temperature, so always keep close to your barbecue and remember to keep the lid on as much as possible so that the heat does not escape.

## Frozen or Fresh

Whether you are barbecuing frozen or fresh food, follow the safety guidelines on the package and always cook it to the recommended internal temperature. Frozen food will take longer to barbecue and may need more fuel to be added depending on the type of food.

## Keeping it Clean

Follow a few basic maintenance instructions to keep your barbecue looking and barbecuing better for years to come!

- For proper air flow and better barbecuing, remove accumulated ashes and old charcoal from the bottom of the kettle and the ash catcher before use. Make sure that all of the charcoal is fully extinguished and the barbecue is cool before doing so.
- You may notice "paint-like" flakes on the inside of the lid. During use, grease and smoke vapours slowly oxidise into carbon and deposit on the inside of your lid. Brush the carbonised grease from the inside of the lid with a stainless steel bristle barbecue brush. To minimise further build-up, the inside of the lid can be wiped with a paper towel after cooking while the barbecue is still warm (not hot).
- If your barbecue is subject to a particularly harsh environment, you will want to clean the outside more often. Acid rain, chemicals, and salt water can cause surface rusting to appear. WEBER recommends wiping down the outside of your barbecue with warm soapy water. Follow up with a rinse and thorough drying.
- Do not use sharp objects or abrasive cleaners to clean the surfaces of your barbecue.

## Smoking with Wood

Experimenting with different woods while smoking is encouraged to find the perfect balance of sweet and savoury. While smoking over long periods of time, be sure to always use wood chunks instead of wood chips. Chunks allow for a longer smoke that penetrates slowly over a long cooking time. Wood chips work best for a shorter cooking time because they do not last as long during a long smoke.



# REPLACEMENT PARTS

57cm\_Master-Touch\_Premium\_E-5770\_XV\_EU\_080118

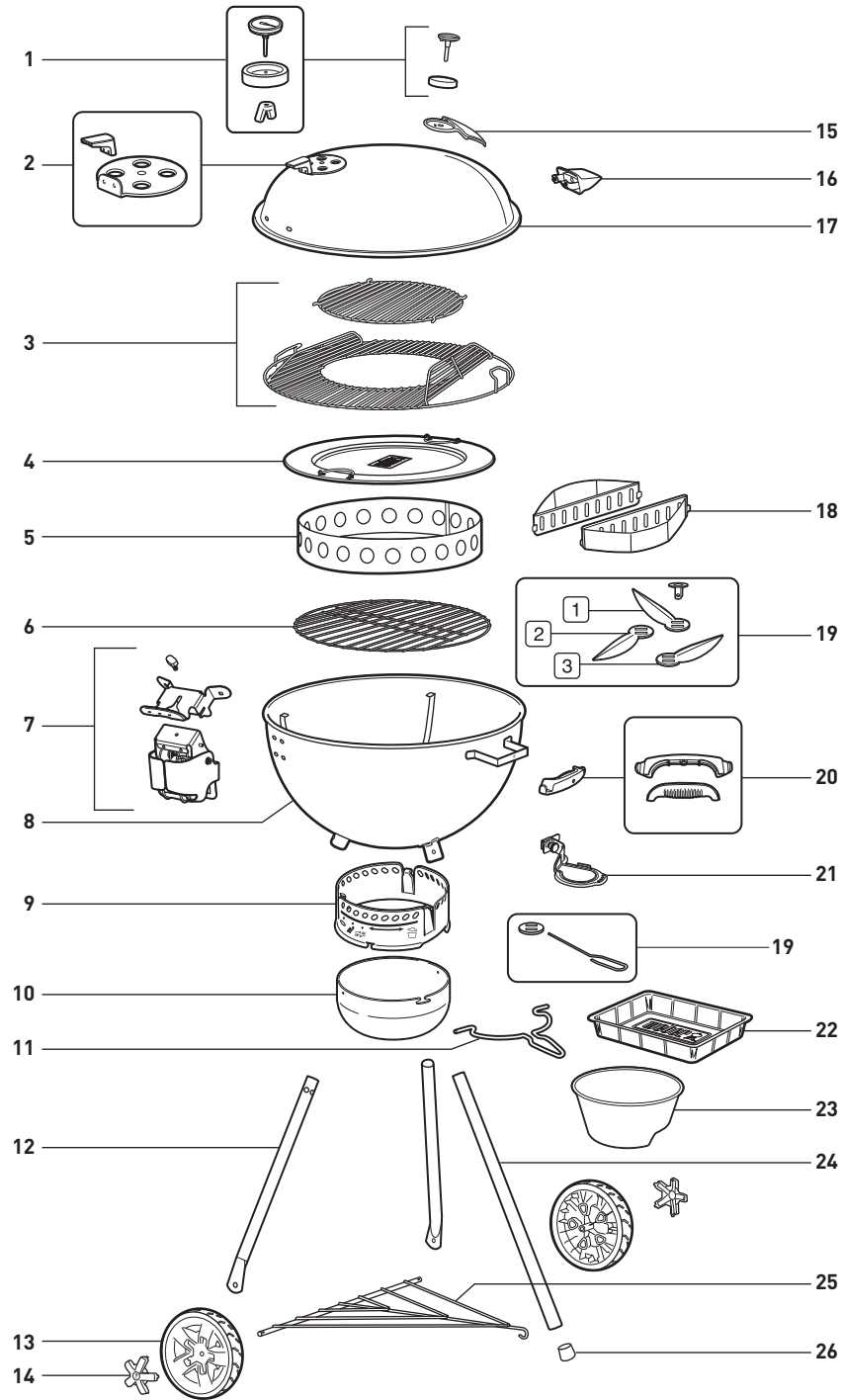





# REPLACEMENT PARTS

57cm\_Master-Touch\_Premium\_SE E-5775\_XV\_EU\_080118

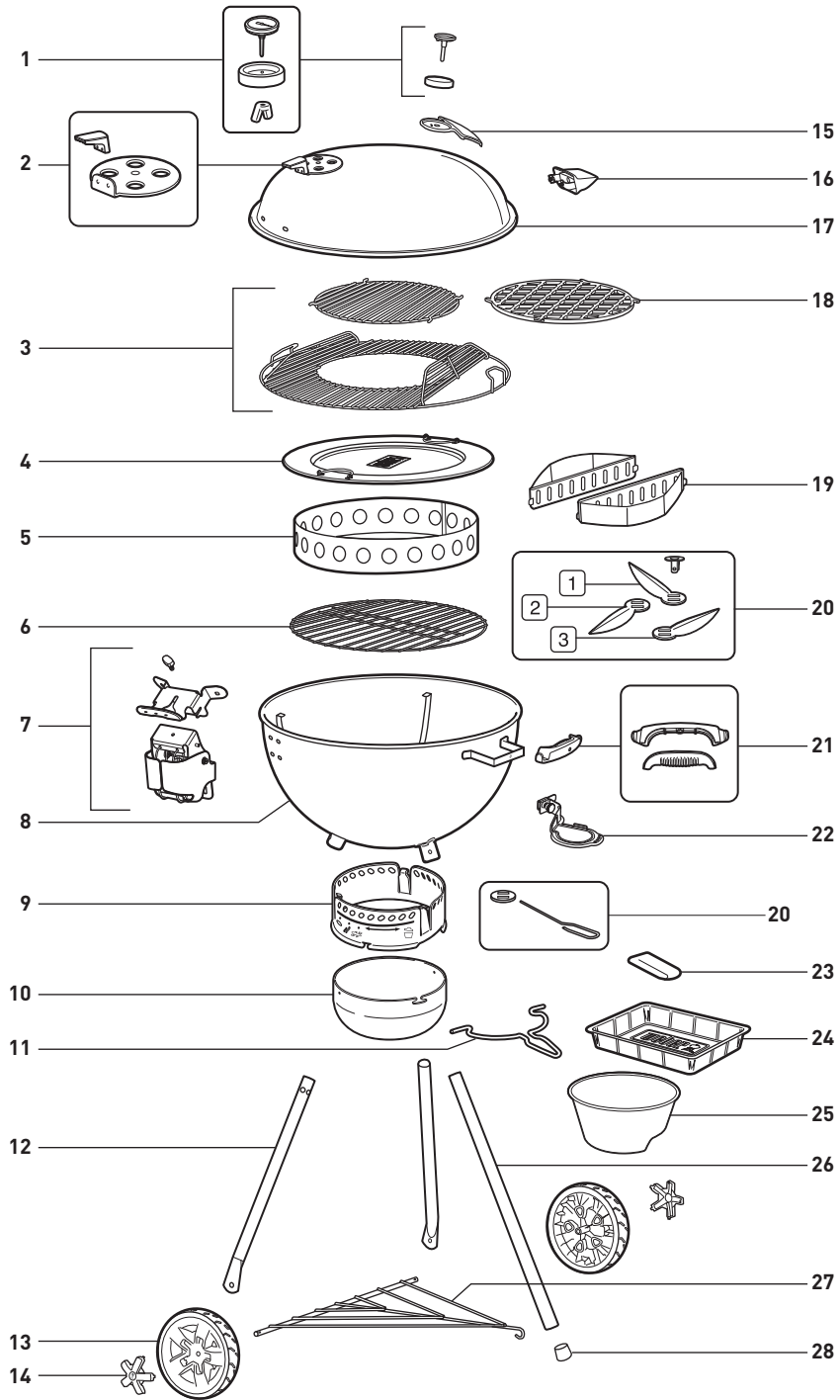





Serial Number

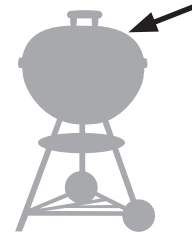

Write your barbecue's serial number in the above box for future reference. The serial number is on the lid damper located on the lid.

#### AUSTRALIA

Weber-Stephen Products LLC  
R. McDonald Co. PTY. LTD.  
+61.8.8221.6111

#### AUSTRIA

Weber-Stephen Österreich GmbH  
+43 (0)7 242 89 0135  
service-at@weber.com

#### BELGIUM

Weber-Stephen Products Belgium Sprl  
+32 15 28 30 90  
service-be@weber.com

#### CHILE

Weber-Stephen Chile SpA.  
+01 56 2-3224-3936

#### CZECH REPUBLIC

Weber-Stephen CZ & SK spol. s r.o.  
+42 267 312 973  
info-cz@weberstephen.com

#### DENMARK

Weber-Stephen Nordic ApS  
+45 99 36 30 10  
service-dk@weber.com

#### FRANCE

Weber-Stephen France SAS  
+33 0810 19 32 37  
service-fr@weber.com

#### GERMANY

Weber-Stephen Deutschland GmbH  
+49 (0) 30 219 0710  
service-de@weber.com

#### HUNGARY

Weber-Stephen Magyarország Kft.  
+36 70 / 70-89-813  
info-hu@weberstephen.com

#### ICELAND

Jarn & Gler Wholesale EHF  
+354 58 58 900

#### INDIA

Weber-Stephen Barbecue Products India Pvt. Ltd.  
080 42406666  
customercare@weberindia.com

#### ISRAEL

D&S Imports  
+972 392 41119  
info@weber.co.il

#### ITALY

Weber-Stephen Products Italia Srl  
+39 0444 367 911  
service-it@weber.com

#### MEXICO

Weber-Stephen Products S.A. de C.V.  
+01800-00-WEBER [93237] Ext. 105

#### NETHERLANDS

Weber-Stephen Holland B.V.  
+31 202 623 978  
service-nl@weber.com

#### NEW ZEALAND

WEBER New Zealand ULC  
+64 9 570 6630

#### POLAND

Weber-Stephen Polska Sp. z o.o.  
+48 22 392 04 69  
info-pl@weberstephen.com

#### RUSSIA

Weber-Stephen Vostok LLC  
+7 495 956 63 21  
info.ru@weberstephen.com

#### SOUTH AFRICA

Weber-Stephen Products (South Africa) Pty Ltd.  
+27 11 454 2369  
info@weber.co.za

#### SPAIN

Weber-Stephen Ibérica SRL  
+34 935 844 055  
service-es@weber.com

#### SWITZERLAND

Weber-Stephen Schweiz GmbH  
+90 52 24402 50  
service-ch@weber.com

#### TURKEY

Weber-Stephen Turkey  
+90 212 059 64 80  
info-de@weberstephen.com

#### UNITED ARAB EMIRATES

Weber-Stephen Deutschland GmbH, Dubai Branch  
+971 4 454 1626  
info@weberstephen.ae

#### UNITED KINGDOM

Weber-Stephen Products (UK) Ltd.  
+44 (0)203 630 1500  
service-uk@weber.com

#### USA

Weber-Stephen Products LLC  
847 934 5700  
support@weberstephen.com

For Republic of Ireland, please contact:  
Weber-Stephen Products (U.K.) Limited.

For other eastern European countries, such as ROMANIA,  
SLOVENIA, CROATIA, or GREECE, please contact:  
Weber-Stephen Deutschland GmbH.

For Baltic states, please contact:  
Weber-Stephen Nordic ApS.

weber.com



WEBER-STEPHEN PRODUCTS LLC  
www.weber.com