

xiaomi Truclean W10 Pro Wet Dry Vacuum User Manual



Safety Instructions

This product is for household use only. Read this manual carefully before use, and retain it for future reference.

- This appliance can be used by children aged from 8 years and above and persons with reduced physical, sensory or mental capabilities or lack of experience and knowledge if they have been given supervision or instruction concerning use of the appliance in a safe way and understand the hazards involved. Children shall not play with the appliance. Cleaning and user maintenance shall not be made by children without supervision.
- This appliance contains batteries that are only replaceable by skilled persons.
- The appliance is only to be used with the power supply unit provided with the appliance.
- Do not touch the plug or any part of the vacuum with wet hands.
- This vacuum is for indoor use only. Do not use or install it in outdoor, industrial, or commercial environments. Do not use the self-cleaning charging dock in humid environments such as bathrooms.
- A hazard may occur if the appliance runs over the supply cord.
- The plug must be removed from socket-outlet before cleaning or maintaining the appliance.
- To reduce the risk of fire, explosion, or personal injury, check before use to make sure the power supply is undamaged. Do not use the vacuum if the power supply is damaged.
- Do not immerse the vacuum or the self-cleaning charging dock in water or other liquids for cleaning.
- Clean the dirty water tank in time to avoid the decrease of suction and overheating of the motor caused by obstruction. Otherwise, the service life of the vacuum may be affected. Do not use the vacuum if the roller brushbar, the dirty water tank, and the filter are not installed in place.
- Make sure to turn off the vacuum before cleaning or replacing the roller brushbar.
- Neither use the vacuum cleaner to pick up flammable or explosive liquids such as gasoline, nor other liquids such as water or toxic liquids like bleach, ammonia, and drain cleaners.
- Do not use the vacuum to clean up toner used in laser printers and copiers, as toner may cause fire or explosion.
- Do not use the vacuum to pick up smoking or burning materials such as charcoal, cigarette butts, or matches.
- Do not use the vacuum to pick up sharp or hard objects, such as glass, nails, screws, or coins, which may damage the vacuum.
- Do not use the vacuum to clean stains of thick oily substances, strong adhesives, or dyes, such as shoe polish, paints and pigments.
- Keep hair, loose clothing, fingers, and other parts of the body away from the vacuum's openings and moving parts.
- Do not put any objects into the vacuum's openings, nor use the vacuum any opening blocked. Keep free of dust, lint, hair, or other items which may reduce airflow.
- Do not shake the vacuum up and down or hit it violently to prevent dirty water from flowing into the motor.
- Do not lift or move the vacuum while the motor is operating, nor tilt it to one side to prevent dirty water from entering the motor.
- Do not place the vacuum on unstable surfaces such as chairs or tables to prevent damage or personal injury caused by its falling of. If the vacuum malfunctions because of being knocked over or damaged, please contact the authorized service department. Never attempt to disassemble the vacuum on your own.
- Do not charge or store the vacuum near heat sources or in humid areas, such as by a radiator or in a kitchen or bathroom.
- Only use replacement parts that are approved by Xiaomi.
- Do not repair the vacuum on your own when it breaks down or has problems like electric leakage, overheating motor, making unusual sounds, overheating main body, giving off odors, or weak suction.
- Keep the cleaning brush out of reach of children.
- Please be extra careful when using the vacuum to clean stairs.
- Do not apply any type of fragrance to the vacuum's filter. These types of products are known to contain flammable chemicals which may cause the vacuum to catch fire.
- Strictly follow the instructions in this user manual to charge the vacuum at an ambient temperature of 6°C to 40°C. Improper charging may result in damage to the battery.
- Please strictly follow the instructions in this user manual when using the vacuum. Users are responsible for any loss or damage that may arise from improper use of the vacuum.
- For detailed e-manual, please go to www.mi.com/global/service/userguide.

WARNING:

Do not use any third-party battery or power supply. Only use the BLJ24WD260090P-V power supply provided with the appliance.

Regulatory Compliance Information



EU Declaration of Conformity

We, Beijing Shuanzao Technology Co., Ltd., hereby declare that this equipment is in compliance with the applicable Directives and European Norms, and amendments. The full text of the EU declaration of conformity is available at the following internet address: <http://www.mi.com/global/service/support/declaration.html>



WEEE Disposal and Recycling Information

All products bearing this symbol are waste electrical and electronic equipment (WEEE as in directive 2012/19/EU) which should not be mixed with unsorted household waste. Instead, you should protect human health and the environment by handing over your waste equipment to a designated collection point for the recycling of waste electrical and electronic equipment, appointed by the government or local authorities. Correct disposal and recycling will help prevent potential negative consequences to the environment and human health. Please contact the installer or local authorities for more information about the location as well as terms and conditions such collection points.

Accessory List

Accessories for installing on the Vacuum

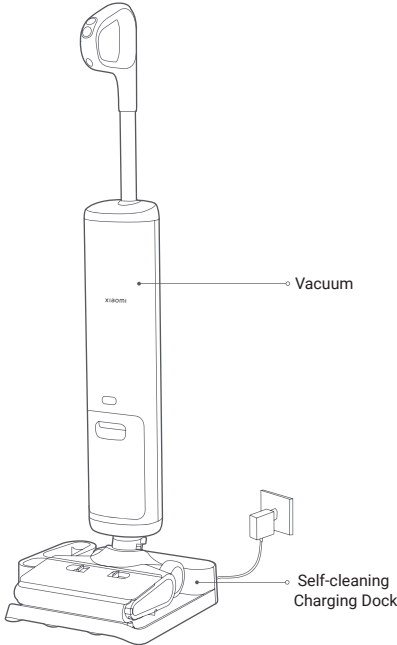

Handle

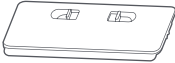

Roller Brushbar Cover
(Pre-installed)



Filter
(Pre-installed)



Clean Water Tank
(Pre-installed)



Dirty Water Tank
(Pre-installed)

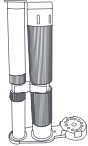

Roller Brushbar Holder



Roller Brushbar
Mop Pad

Accessories for Installing on the Self-cleaning Charging Dock

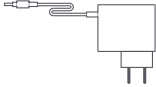

Power Supply



Accessory Container



Mounting Clip

Other Accessories



Cleaning Brush
(Rotate the handle of the cleaning brush to
remove blade)

Note: Illustrations of product, accessories, and user interface in the user manual are for reference purposes only. Actual product and functions may vary due to product enhancements.

Product Overview

Vacuum

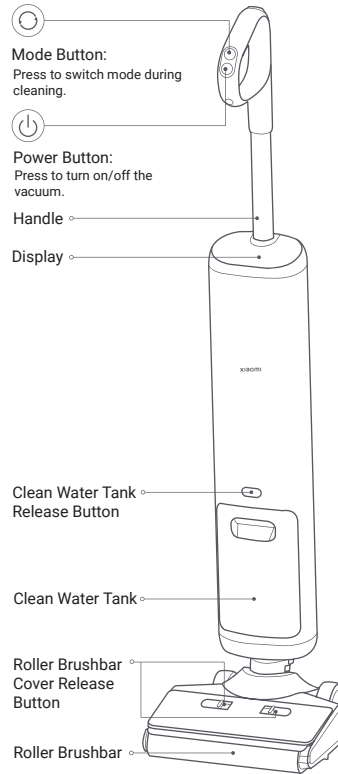
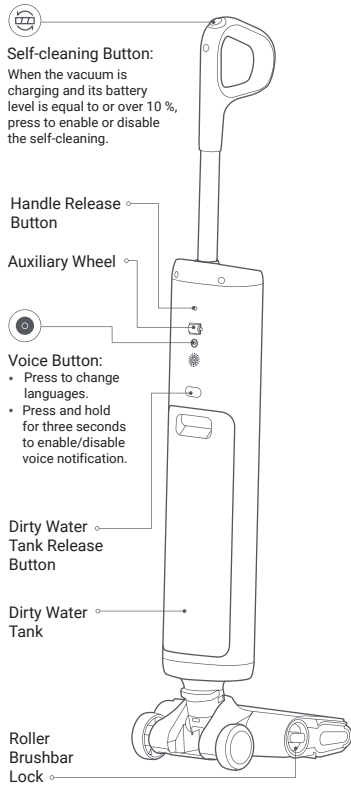

Display

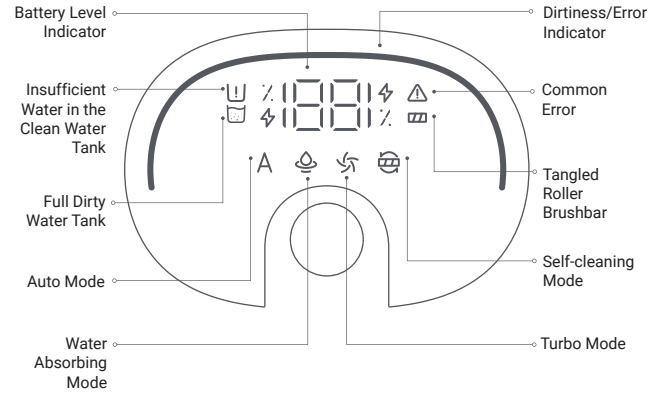

Dirtiness/Error Indicator

Green: Clean
Yellow: Dirty
Orange: Very dirty
Red: Error

Self-cleaning Charging Dock

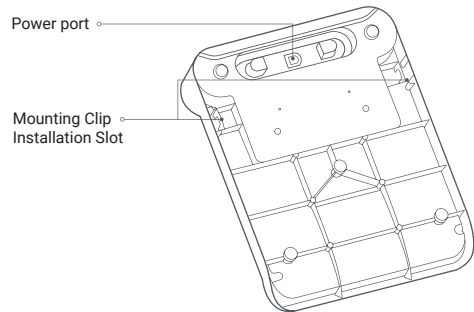
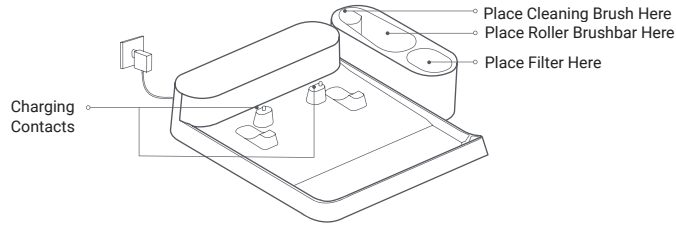

Clean Water Tank

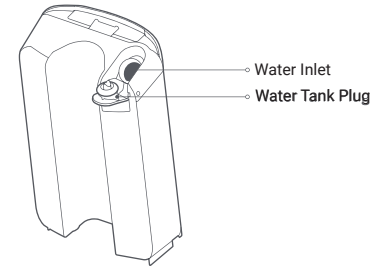

Dirty Water Tank

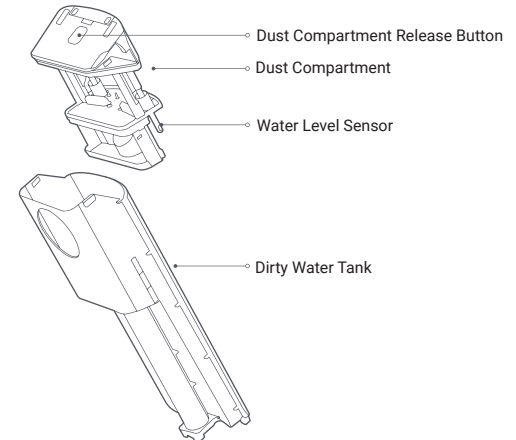

How to Install

Installing the Roller Brushbar

Warning: Turn on the vacuum after installing the roller brushbar onto the floor brush and making sure it is secured in place.

1. Pinch both roller brushbar cover release buttons to remove the roller brushbar cover.

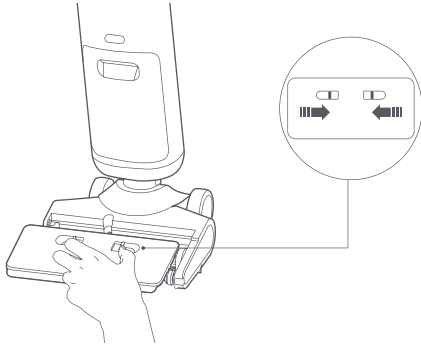

2. Remove the inner holder inside the roller brushbar mop pad.



3. Hold the roller brushbar holder by its upper part, put into the roller brushbar mop pad, and press them into place.

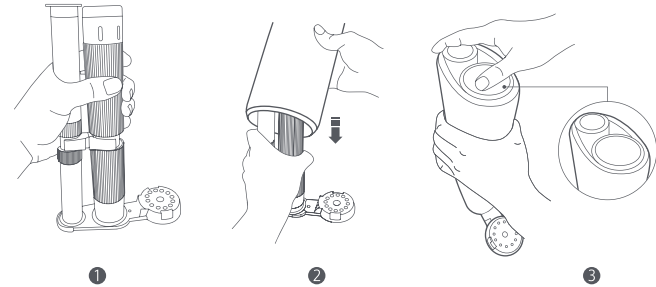

4. Install the roller brushbar onto the floor brush, and turn the roller brushbar lock to the locked position. Then reinstall the roller brushbar cover.

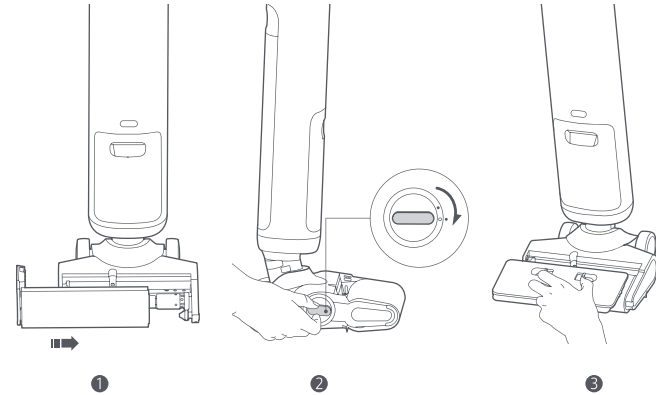

Installing the Handle

Insert the handle into the vacuum. The handle is installed when you hear a click.
Caution: Make sure that the handle is secured in place after installation.

To remove the handle, use a non-sharp tool, such as a chopstick, to press and hold the handle release button on the back of the vacuum, and simultaneously pull the handle upwards vertically.

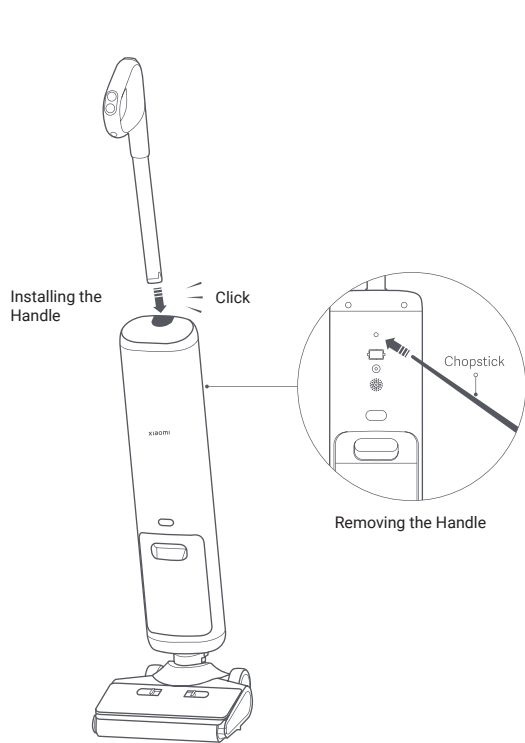

Installing the Self-cleaning Charging Dock

1. Installing the Power Cord

Plug the power cord into the power port at the bottom of the self-cleaning charging dock, then wind and store the excess power cord.

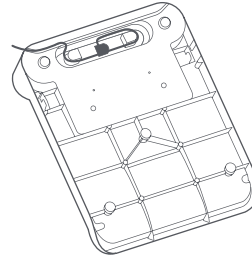

2. Installing the Mounting Clip

Install the mounting clip onto the installation slot on either side of the bottom of the self-cleaning charging dock.

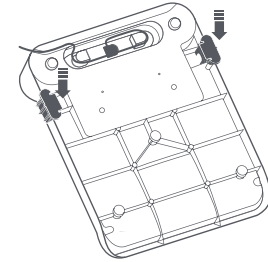

3. Installing the Accessory Container

Install the accessory container onto the mounting clip.

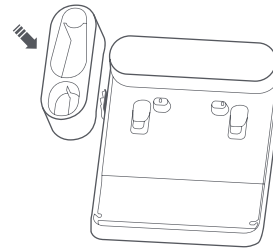

4. Storing the Accessories

The container can store the cleaning brush, the roller brushbar, and the filter.

Note:

The spare roller brushbar and the spare filter need to be purchased separately.

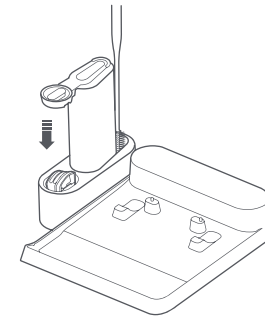

5. Connecting to an Electrical Outlet

Place the self-cleaning charging dock on a flat surface and connect it to power via the power supply.

Note:

Do not place the self-cleaning charging dock near heat sources or in humid areas, such as by a radiator, in a kitchen, or in a bathroom.

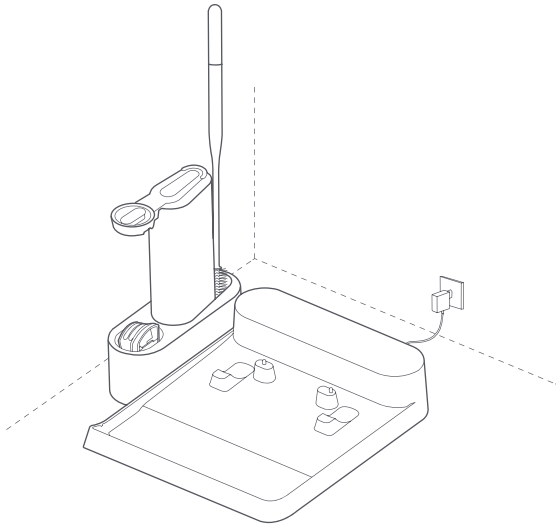

6. Charging on the Self-cleaning Charging Dock

After the self-cleaning charging dock is plugged in, align the charging contacts at the bottom of the vacuum's floor brush with the charging contacts on the dock. The vacuum starts charging when you hear the voice prompt.

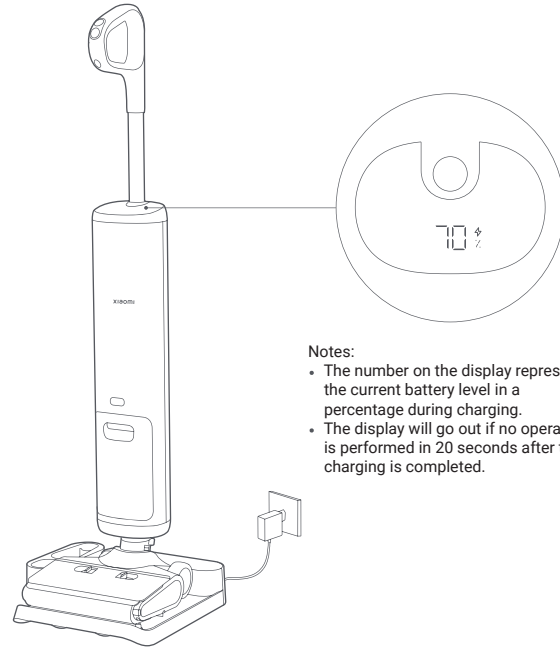

Notes:

- The number on the display represents the current battery level in a percentage during charging.
- The display will go out if no operation is performed in 20 seconds after the charging is completed.

Notes:

- Fully charge the vacuum before first use and after each use. The total charging time is about 5 hours.
- Working at the turbo mode for a prolonged period will cause the battery to heat up, and the charging time may increase or the battery level may not grow in a short time during charging. This is normal.

How to use

Water Adding

1. Press the clean water tank release button, and simultaneously pull the tank out.

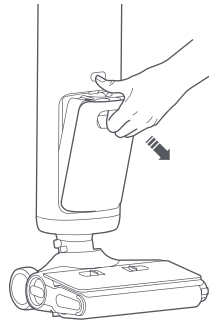

2. Open the clean water tank plug, slowly fill the tank with clean water up to the maximum water level mark, and insert the plug back. Then reinstall the clean water tank to the vacuum. It is secured in place when you hear a click.

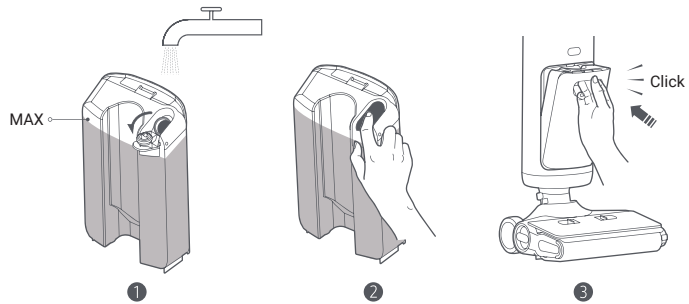

Note: Do not add hot water or disinfectant to avoid damaging the vacuum and other components.

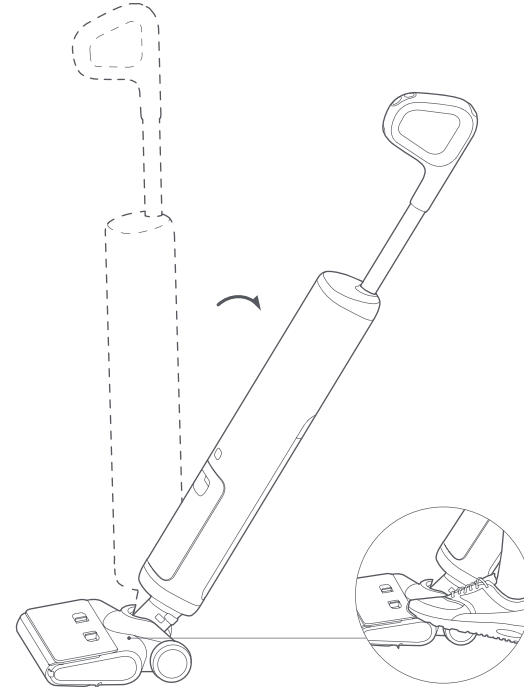

Turning on

- Remove the vacuum from the self-cleaning charging dock, step on the floor brush with one foot and pull back the handle to tilt the vacuum.
- Press the button  to turn on the vacuum.



Switching Modes

- Press the button  to cycle through the modes of auto, water absorbing, and turbo.

 Auto Mode	 Water Asorbing Mode	 Turbo Mode
Daily stains cleaning	Water stains cleaning (not for vacuuming dust)	Stubborn stains cleaning

CAUTION:

Do not rotate the vacuum from side to side while lying it down for cleaning to prevent the floor brush from tilting up or dirty water from running out.

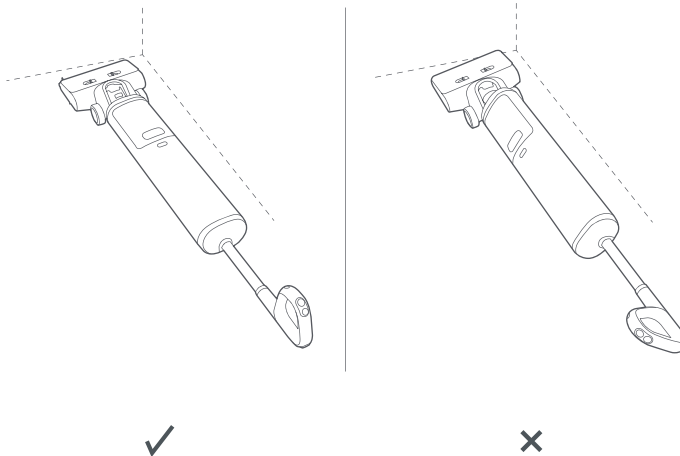

Pausing/Turning off

- 1 Hold the vacuum in the upright position to pause cleaning, or press the button  to turn off the vacuum. To avoid dirty water residues, the vacuum will continue running for a few seconds before turning off. Place the vacuum back onto the self-cleaning charging dock after it completely stops working.
- 2 When the vacuum is paused in the upright position or turned off, pull the handle backward, and push the vacuum to the self-cleaning charging dock with the help of wheels. Then you can use the dock for storage, charging, and self-cleaning.

Notes:

- Put the vacuum back onto the self-cleaning charging dock properly after using it to prevent the vacuum from tipping over due to improper placement.
- Do not lift the vacuum vertically as illustrated to prevent dirty water from flowing out.

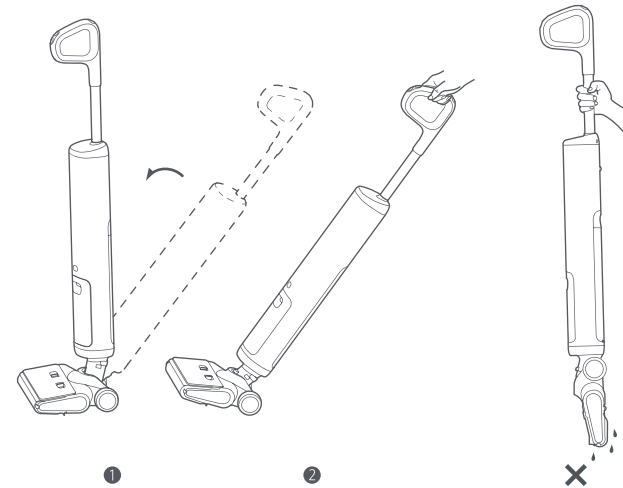

Using Scenarios

The vacuum can be used to clean different types of hard-surface flooring such as wood, tile, and marble.

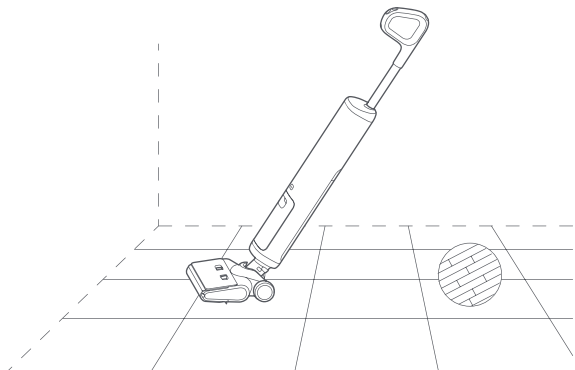

The vacuum can be placed flat at 180° for cleaning the floor underneath the furniture.

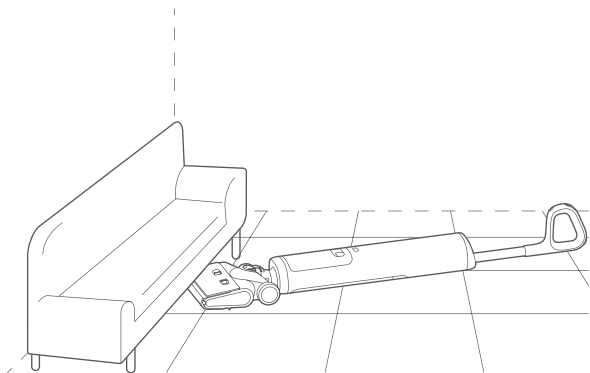

Cautions:

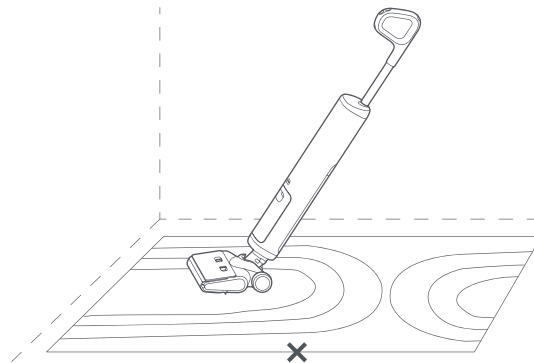

- Do not use the vacuum on fabric surfaces, such as carpets and blankets.

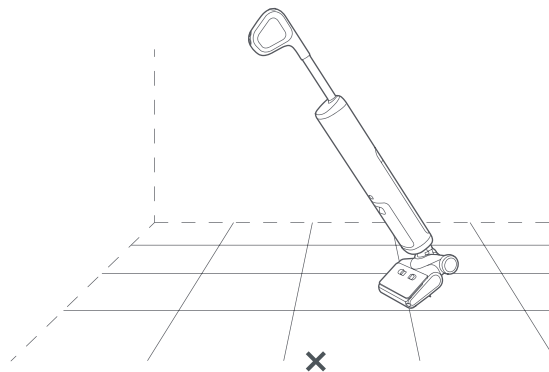

- Do not tilt the vacuum forward or shake it violently while cleaning to avoid dirty water flowing into the vacuum and thus damaging it.



Self-cleaning

- When the vacuum is charging and its battery level is equal to or more than 10%, press  to start self-cleaning.
- Press the button  or the button  to stop self-cleaning.
- Based on how dirty the roller brushbar is, it will take about 2 to 3 minutes for the vacuum to complete the self-cleaning.

Notes:

- Clean the dirty water tank in time after self-cleaning to prevent odors.
- It is recommended to remove the roller brushbar after self-cleaning and place it in the accessory container for drying to prevent odors.
- It is recommended to regularly clean parts that cannot be cleaned by self-cleaning, such as the roller brushbar cover and the parts around the cushion port.

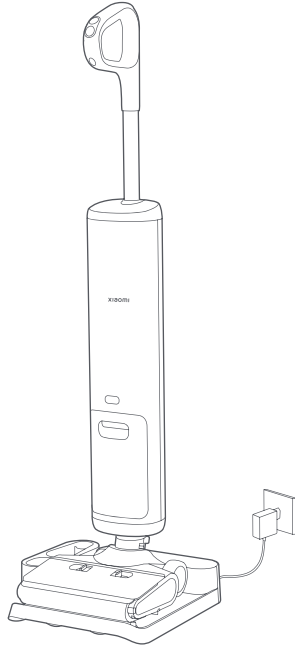

Care & Maintenance

- Clean and maintain the relevant components when the vacuum is paused in the upright position or turned off.
- Move the self-cleaning charging dock away before cleaning the vacuum.

Maintenance Frequency

Component	Recommended Maintenance Frequency
Dirty water tank components (including the dirty water tank, the dust compartment, and the water level sensor)	Clean after each use.
Dirty water outlet pipeline (including the dirt detection sensor)	Clean when prompted by relevant voice notification.
Water & air separator	1-3 months
Floor brush (overall)	Clean once a week, depending on the dirtiness.
Roller brushbar	Self-cleaning is required after each use.
Filter	Clean once a week.
Self-cleaning charging dock	Clean once a week.

Replacement Frequency

The following recommended replacement frequencies are for reference only. Components should be replaced promptly if damaged.

Component	Recommended Replacement Frequency
Roller Brushbar	3-6 months
Filter	6-12 months

Cleaning the Dirty Water Tank

1. Press the dirty water tank release button, and simultaneously pull the tank out.

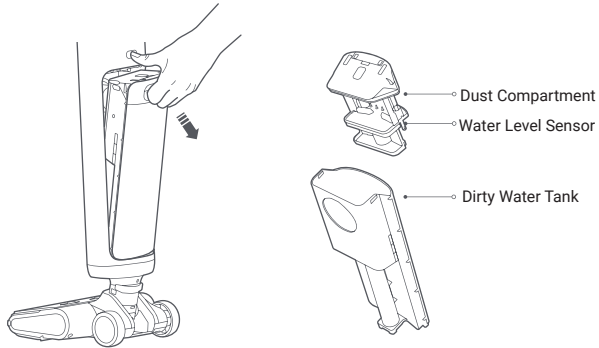

2. Hold the lower end of the dirty water tank with one hand, press the dust compartment release button with the other, and remove the dust compartment upwards. Then empty the dust and dirty water respectively.

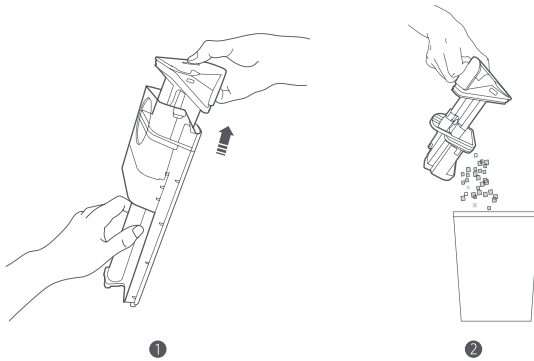

3. Rinse the dirty water tank, the dust compartment, and the water level sensor until they are clean.

Notes:

- The cleaning brush can be used to assist in cleaning.
- The water level sensor should be cleaned frequently to avoid the detection accuracy being affected by the stains adhered to the sensor.

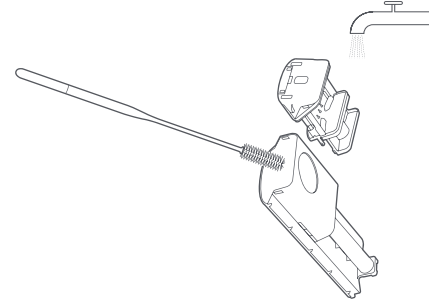

4. Put the dust compartment back, then reinstall the dirty water tank onto the vacuum. The tank is secured in place when you hear a click.

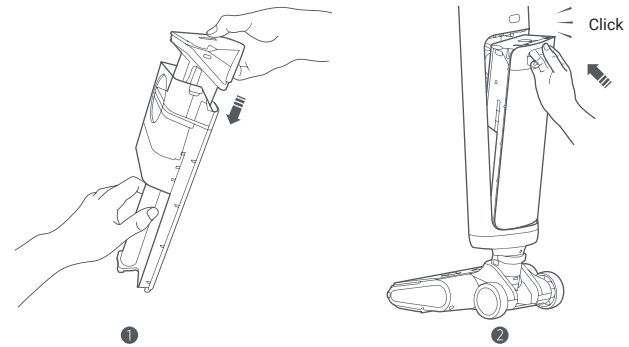

Cleaning the Floor Brush

1. Pinch both roller brushbar cover release buttons to remove the roller brushbar cover.

Note:

Do not remove the roller brushbar while the vacuum is on the self-cleaning charging dock.

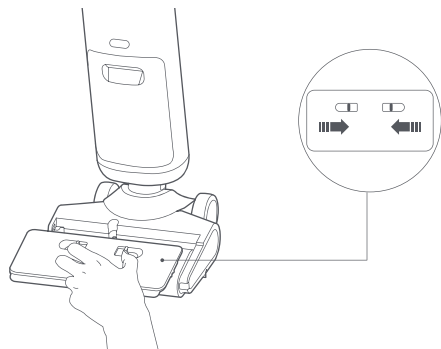

2. Turn the roller brushbar lock counterclockwise until it is unlocked, and pull the roller brushbar outward.

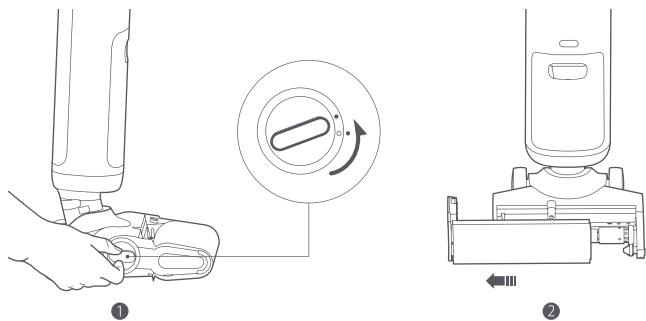

3. Rotate the handle of the cleaning brush to remove the blade. Use the blade to cut the hair tangled on the roller brushbar and the floor brush.

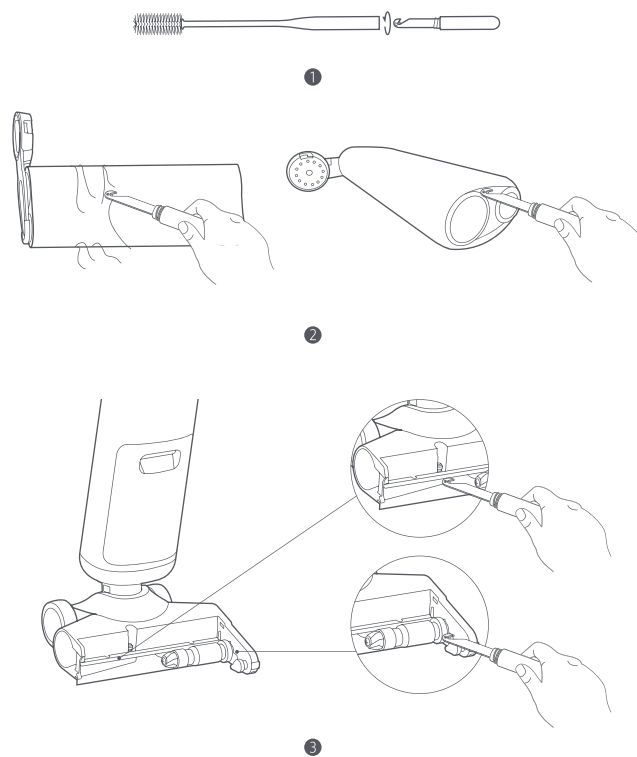

4. Use tap water to rinse the roller brushbar and its cover until they are clean, and then put them in the accessory container for drying to prevent odors.
Note: Do not expose the roller brushbar to direct sunlight.

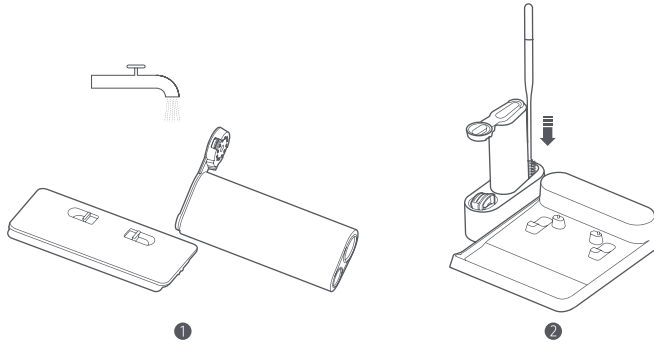

5. Use a dry cloth or paper towel to remove the hair, dirt, and foreign objects blocked at the suction port.
Notes:
- Do not rinse the floor brush directly.
 - Do not touch the gearbox right after using the vacuum to avoid scalds.

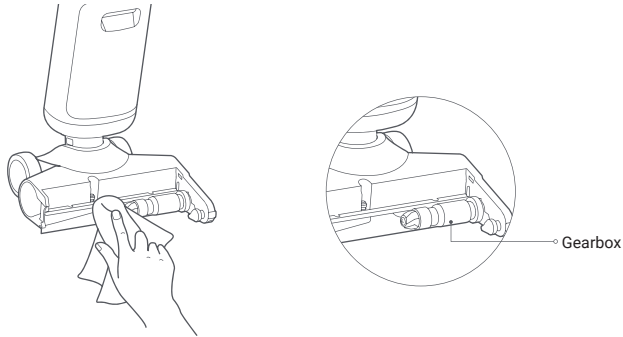

6. Reinstall the roller brushbar and its cover in order. When reinstalling the roller brushbar cover, align it with the mounting position, and it is secured in place when you hear a click.

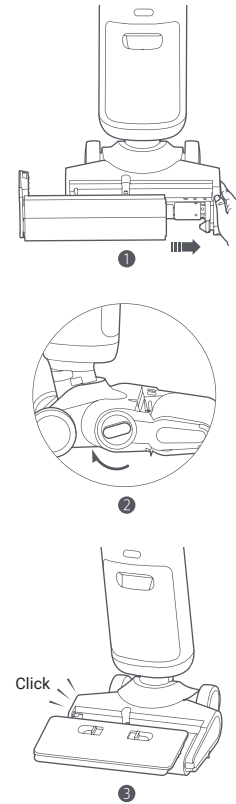

Cleaning the Water & Air Separator

It is normal to find a small amount of dirty water around the water & air separator after removing the dirty water tank. Please wipe the dirty water away.

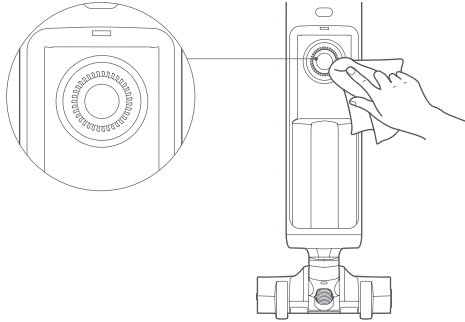

Cleaning the Dirt Detection Sensor

Take out the dirty water tank, and use the cleaning brush to clean the dirt detection sensor and the pipeline of the dirty water outlet.

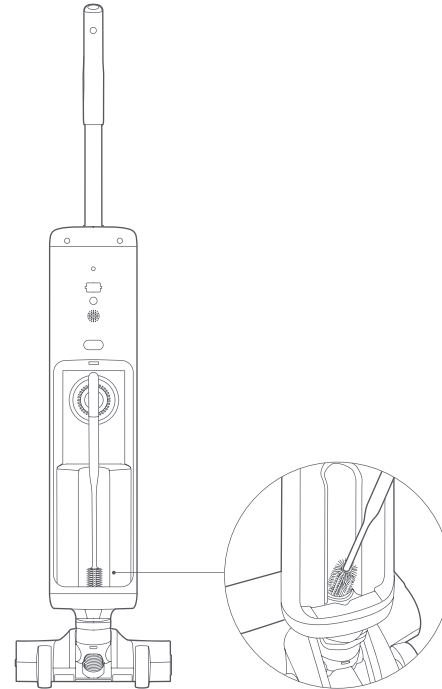

Cleaning the Filter

Pull out the filter from the top left corner of the dirty water tank's mounting slot as illustrated. Rinse the filter clean under tap water, then dry it or put it in the accessory container to dry before reinstalling to prevent odors.

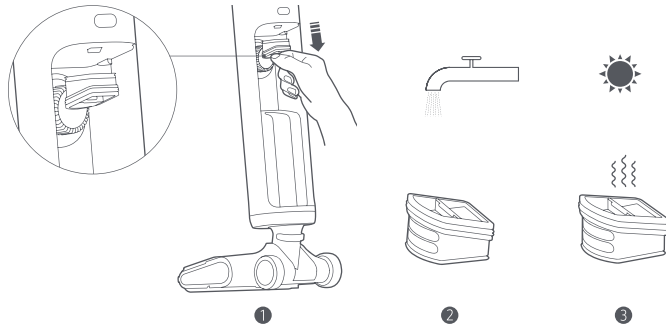

Cleaning the Self-cleaning Charging Dock

Disconnect the self-cleaning charging dock from the power supply before cleaning the dock. Use a dry cloth or paper towel to clean the dust from the self-cleaning charging dock.

Note:

Do not rinse the self-cleaning charging dock directly with water to prevent short circuits.

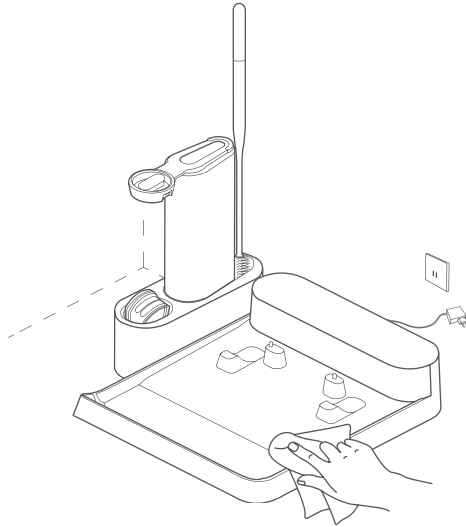



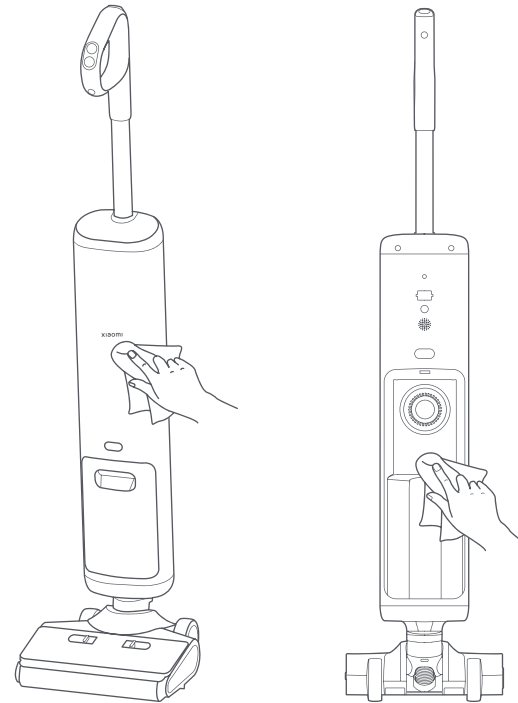

Cleaning the Vacuum

Stand the vacuum upright, and use a dry cloth or paper towel to clean the dust from the vacuum.



Troubleshooting

The display will show an error message or a voice notification will be played when the vacuum is not working normally, please refer to the table to find the solution. If the error cannot be solved by the solution, please contact the after-sales service team in time.

Error Icon	Voice Notification	Solution
	The clean water tank is short of water, please add water.	Add water to the clean water tank before use.
	The roller brushbar is tangled with foreign objects, please check and clean it.	Check and clean the roller brushbar.
	The dirty water tank is full, please clean it.	Clean the dirty water tank and reinstall it.
	Reinstall the roller brushbar.	Reinstall the roller brushbar properly.
	The air vent is blocked, please clean the pipeline and the dirty water tank.	Check whether the suction port of the floor brush and the pipeline of the dirty water outlet are blocked, and clean the dirty water tank.
	The sensor is dirty, please clean the pipeline of the vacuum.	Clean the dirt detection sensor.
	The vacuum malfunctions, and it has voice alert with error code.	Contact the after-sales service team.

Please refer to the table below to find the troubleshooting for common issues.

Common Issue	Possible Cause	Solution
The vacuum does not work.	The battery is depleted.	Fully charge the vacuum before use.
	The battery has overheating protection.	Try again after the battery temperature returns to normal.
	Clean water tank, dirty water tank, or roller brushbar is not installed.	Install the clean water tank/dirty water tank/roller brushbar properly.
	The dirty water tank is full.	Clean the dirty water tank and reinstall it.
	The clean water tank is out of water.	Add water to the clean water tank and reinstall the tank.
	The suction port of the floor brush or the pipeline of the dirty water outlet is blocked.	Clean the suction port of the floor brush and the pipeline of the dirty water outlet.
The vacuum cannot recycle dirty water properly.	The roller brushbar is tangled with foreign objects.	Clean the roller brushbar.
	The filter is not installed.	Install the filter before use.
A false alert for a full dirty water tank is triggered.	The water level sensor is dirty.	Clean the water level sensor.
The vacuum cannot be charged.	The self-cleaning charging dock is not connected to power.	Use the original power supply to charge the self-cleaning charging dock.
	The power supply being used is not original.	Use the original power supply.
The vacuum has no voice notification.	The voice notification is disabled.	Press and hold the voice button for three seconds to enable voice notification.
The vacuum cannot carry out self-cleaning.	The clean water tank is out of water.	Add water to clean water tank and reinstall the tank.
	The clean water tank is not installed.	Reinstall the clean water tank.
	The dirty water tank is full.	Clean the dirty water tank and reinstall it.
	The dirty water tank is not installed.	Reinstall the dirty water tank.
	The battery is low or depleted.	Carry out self-cleaning when the battery level is sufficient.
	The self-cleaning charging dock is not connected to power.	Use the original power supply to charge the self-cleaning charging dock.

Specifications

Xiaomi Truclean W10 Pro Wet Dry Vacuum			
Name	Wet and Dry Vacuum Cleaner	Model	B302GL
Rated Voltage	21.6 V ⁼⁼	Rated Power	200 W
Charging Voltage	26.0 V ⁼⁼	Net Weight (Vacuum)	5,4 kg
IP Class	IPX4	Net Weight (with Accessories)	6,4 kg
Self-cleaning Charging Dock			
Name	Charging Dock	Model	B302CN-JZ
Rated Input	26.0 V ⁼⁼ 0.9 A	Rated Output	26.0 V ⁼⁼ 0.9 A
Net Weight	0,65 kg		
Power Supply			
Manufacturer	Zhongshan Baolijin Electronic Co., Ltd.	Average Active Efficiency	87.00%
Model	BLJ24WD260090P-V	Efficiency at Low Load (10%)	79.20%
Input	100-240 V ~ 50/60Hz 0.8 A	No-load Power Consumption	0.06 W
Output	26.0 V ⁼⁼ 0.9 A 23.4 W		

Environmental Notice

The lithium-ion battery pack contains substances that are hazardous to the environment. Before disposing of the vacuum, please first remove the battery pack, then discard, or recycle it in accordance with local laws and regulations of the country or region it is used in.

- Before disposing of the vacuum, remove the battery first.
- The vacuum must be turned off before removing the battery.
- The battery should be disposed of safely.

CAUTIONS:

- Remove the entire battery pack together, and make sure not to damage the outer casing of the battery pack to prevent short-circuiting or leakage of harmful substances.
- In the event of a battery leak, avoid contact with the liquid. If the liquid enters the eyes, rinse with plenty of water and seek medical attention immediately.
- The battery should not be removed by non-professionals. Otherwise, it may lead to a short circuit or other risks. It is recommended to send the product to the professional after-sales service team or a government-approved recycling facility for removal.

Steps to Remove the Battery:

1. Use a non-sharp tool to press and hold the handle release button on the back of the vacuum, and simultaneously pull the handle upwards vertically.
2. Remove the dirty water tank.
3. Unscrew the display assembly to remove it.
4. Remove the rear cover of the vacuum by unscrewing the bottom cover, the front cover, and the rear cover of the vacuum.
5. Unscrew the battery pack assembly to remove it.
6. Unscrew the top and bottom covers of the battery pack assembly and remove the top cover.
7. Unscrew the battery pack assembly, and unplug the battery pack to remove it.

WARRANTY NOTICE

THIS WARRANTY GIVES SPECIFIC RIGHTS, AND YOU MAY HAVE OTHER RIGHTS CONVEYED BY LAWS OF YOUR COUNTRY, PROVINCE OR STATE. INDEED, IN SOME COUNTRIES, PROVINCES OR STATES, CONSUMER LAW MAY IMPOSE A MINIMUM WARRANTY PERIOD. OTHER THAN AS PERMITTED BY LAW, XIAOMI DOES NOT EXCLUDE, LIMIT OR SUSPEND OTHER RIGHTS YOU MAY HAVE. FOR A FULL UNDERSTANDING OF YOUR RIGHTS WE INVITE YOU TO CONSULT THE LAWS OF YOUR COUNTRY, PROVINCE OR STATE.

1. LIMITED PRODUCT WARRANTY

XIAOMI warrants that the Products are free from defects in materials and workmanship under normal use and use in accordance with respective Product user manual, during the Warranty Period. The duration and conditions related to the legal warranties are provided by respective local laws. For more information about the consumer warranty benefits, please refer to Xiaomi's official website <https://www.mi.com/en/service/warranty/>.

Xiaomi warrants to the original purchaser that its Xiaomi Product will be free defects in materials and workmanship under normal use in the period mentioned above.

Xiaomi does not guarantee that the operation of the Product will be uninterrupted or error free.

Xiaomi is not liable for damages arising from non-compliance with the instructions related to the use of the Product.

2. REMEDIES

If a hardware defect is found and valid claim is received by Xiaomi within the Warranty Period, Xiaomi will either (1) repair the product at no charge, (2) replace the product, or (3) refund the Product, excluding potential shipping costs.

3. HOW TO OBTAIN WARRANTY SERVICE

To obtain warranty service, you must deliver the Products, in its original packaging or similar packaging providing an equal degree of Product protection, to the address specified by Xiaomi. Except to the extent prohibited by applicable law, Xiaomi may require you to present proofs or proof of purchase and / or comply with registration requirements before receiving warranty service.

4. EXCLUSIONS AND LIMITATIONS

Unless otherwise stipulated by Xiaomi, this Limited Warranty applies only to the Product, manufactured by or for Xiaomi and identifiable by trademarks, trade name or "Xiaomi" or "Mi" logo.

The Limited Warranty does not apply to any (a) Damage due to acts of nature or God, for example, lightning strikes, tornadoes, flood, fire, earthquake or other external causes; (b) Negligence; (c) Commercial use; (d) Alterations or modifications to any part of the Product; (e) Damage caused by use with non-Xiaomi products; (f) Damage caused by accident, abuse or misuse; (g) Damage caused by operating the Product outside the permitted or intended uses described by Xiaomi or with improper voltage or power supply; or (h) Damage caused by service (including upgrades and expansions) performed by anyone who is not a representative of Xiaomi.

It is your responsibility to backup any data, software, or other materials you may have stored or preserved on the product. It is likely that the data, software or other materials in the equipment will be lost or reformatted during the service process, Xiaomi is not responsible for such damage loss.

No Xiaomi reseller, agent, or employee is authorized to make any modification, extension, or addition to this Limited Warranty. If any term is held to be illegal or unenforceable, the legality or enforceability of the remaining terms shall not be affected or impaired.

Except as prohibited by laws or otherwise promised by Xiaomi, the after-sales services shall be limited to the country or region of the original purchase.

Products which were not duly imported and/or were not duly manufactured by Xiaomi and/or were not duly acquired from Xiaomi or a Xiaomi's official seller are not covered by the present warranties. As per applicable law you may benefit from warranties on the non-official retailer who sold the product. Therefore, Xiaomi invites you to contact the retailer from whom you purchased the product.

The present warranties do not apply in Hong Kong and Taiwan.

5. IMPLIED WARRANTIES

Except to the extent prohibited by applicable law, all implied warranties (including warranties of merchantability and fitness for a particular purpose) will have a limited duration up to a maximum duration of this limited warranty. Some jurisdictions do not allow limitations on the duration of an implied warranty, so the above limitation will not be applied in these cases.

6. DAMAGE LIMITATION

Except to the extent prohibited by applicable law, Xiaomi shall not be liable for any damages caused by accidents, indirect, special or consequential damages, including but not limited to loss of profits, revenue or data, damages resulting from any breach of express or implied warranty or condition, or under any other legal theory, even if Xiaomi has been informed of the possibility of such damages. Some jurisdictions do not allow the exclusion or limitation of special, indirect, or consequential damages, so the above limitation or exclusion may not apply to you.

7. XIAOMI CONTACTS

For customers, please visit the website: <https://www.mi.com/en/service/warranty/>

The contact person for the after-sale service may be any person in Xiaomi's authorized service network, Xiaomi's authorized distributors or the final vendor who sold the products to you. If in doubt please contact the relevant person as Xiaomi may identify.

Manufactured for: Xiaomi communications Co., Ltd.

Manufactured by: Beijing Shunzao Technology Co., Ltd.
(a Mi Ecosystem company)

Address: 101, 1st floor, Building 1, No.16, Anningzhuang East Road, Haidian
District, 100089 Beijing, PEOPLE'S REPUBLIC OF CHINA

For further information, please go to www.mi.com

User Manual Version: V1.0

Importer:

Beryko s.r.o.

Pod Vinicemi 931/2, 301 00 Plzeň

www.beryko.cz



E-manual QR Code